

Exhibit "A"



NEW CHILLER FOR STUDIO 18

INVITATION FOR BID # RE-25-07

Issuance of Solicitation: Tuesday, October 21, 2025
Questions Due Date: Monday, November 24, 2025
Bid Submission Deadline: Tuesday, December 9, 2025

THE CITY OF PEMBROKE PINES
PROCUREMENT DEPARTMENT
8300 SOUTH PALM DRIVE
PEMBROKE PINES, FLORIDA 33025
(954) 518-9020

For more information, please visit our online supplier portal, located at
<https://procurement.opengov.com/portal/pembrokepines>

Table of Contents

1. NOTICE
2. GENERAL PROJECT INFORMATION & TIMELINE
3. PURPOSE AND BACKGROUND
4. SCOPE OF WORK
5. PRICE PROPOSAL / BID TABLE
6. SUBMITTAL DOCUMENTS
7. EVALUATION OF PROPOSALS & PROCESS SELECTION
8. INSURANCE REQUIREMENTS
9. GENERAL TERMS AND CONDITIONS
10. SPECIAL TERMS & CONDITIONS

Attachments:

A - Studio_18_-_Chiller_Installation

B - Standard Release of Lien

C - Specimen Contract - Construction Agreement

D - Sample Insurance Certificate



SECTION 1 - NOTICE

Notice is hereby given that the City Commission of the City of Pembroke Pines is seeking sealed proposals for:

IFB # RE-25-07

New Chiller for Studio 18

Solicitations may be found on the City of Pembroke Pines website under the Procurement Department at <http://www.ppines.com/index.aspx?NID=667>, and may be downloaded directly from the OpenGov platform at <https://procurement.opengov.com/portal/pembrokepines>.

For Technical Support, proposers can reach the OpenGov Service Desk between 7:00 am to 10:00 pm from Monday through Friday via the following methods:

- Chat (preferred method): Click the button in the lower right-hand corner of the portal.
- E-mail: procurement-support@opengov.com
- Phone: 1 (650) 336-7167

If additional help is needed with downloading the solicitation package please contact the Procurement Department at (954) 518-9020 or by email at purchasing@ppines.com. The Procurement Department hours are between 7:00 am to 6:00 pm on Monday through Thursday and is located at 8300 South Palm Drive, Pembroke Pines, FL 33025.

Bidders shall submit all questions regarding this bid via the City's e-Procurement Portal, located at <https://procurement.opengov.com/portal/pembrokepines>. Please note the deadline for submitting questions. All answers will be posted on the City's e-Procurement Portal. Bidders may also click "Follow" on this bid to receive an email notification when answers are posted. It is the bidder's responsibility to check the portal for updates. Only written responses issued through the OpenGov platform will be considered official for interpretations or clarifications.

Proposals will be accepted until 2:00 pm on Tuesday, December 9, 2025, electronically at <https://procurement.opengov.com/portal/pembrokepines/projects/199987>.

Bid Opening: The sealed electronic proposals will be publicly opened at 2:30 pm, on the bid due date, by the City Clerk's Office, in the **City Clerk's Office Conference Room located on the 4th Floor in the Charles F. Dodge City Center**/City Hall Administration Building, located at 601 City Center Way, Pembroke Pines, Florida, 33025.

Virtual Bid Opening: In light of public health concerns and to ensure accessibility for all, the City encourages interested parties and the public to participate virtually via live streaming instead of attending the meeting in person. As a result, meetings may be a combination of in-person and virtual, all as provided by law. To virtually attend the bid opening, please use the Cisco Webex Meetings platform.

Virtual Meeting Details:



- WebEx Meeting Link: <https://ppines.webex.com/meet/purchasing>
- Cisco Webex Meeting Number: 717 019 586
- Join by Phone Number: +1-408-418-9388

The public may download the **Cisco Webex Meetings app** from <https://www.webex.com/downloads.html/>.

To ensure an efficient meeting process, participants are requested to mute their audio and camera during the meeting. While the public is welcome to attend the virtual bid opening, **please note that active participation and commenting will not be allowed during the proceedings.**

For further information about the bid opening or assistance in accessing the virtual meeting, please contact:

Ivan Ospinal or other Procurement Staff in the Procurement Department
City of Pembroke Pines
8300 South Palm Drive,
Pembroke Pines, FL 33025
(954) 518-9020 or 954-518-9020
purchasing@ppines.com



SECTION 2 - GENERAL PROJECT INFORMATION & TIMELINE

2.1 Project Timeline

The work shall be completed within **60** calendar days from issuance of the City's Notice to Proceed (NTP), with an estimated start date of **TBD**.

2.2 Tentative Schedule of Events

Issuance of Solicitation (Posting Date):	October 21, 2025
Pre-Bid Meeting (Mandatory):	October 30, 2025, 10:00am 1101 Poinciana Drive, Pembroke Pines, FL 33025
Question Due Date:	November 24, 2025, 11:30pm
Issuance of Final Answers to Questions:	November 27, 2025
Bid Submission Deadline:	December 9, 2025, 2:00pm
Bid Opening:	Will be held at 2:30 pm on the day of bid submissions are due.
Evaluations by Staff:	To Be Determined (TBD)

2.3 Mandatory Pre-Bid Meeting/Site Visit

There will be a **MANDATORY** scheduled pre-bid meeting on **Thursday, October 30, 2025 at 10:00 am**. Meeting location will be at the **1101 Poinciana Drive, Pembroke Pines, FL 33025**

- A. **Proof of Attendance:** Vendors may be required to sign in at any of the meetings to show proof of attendance. It is the **Vendor's** responsibility to make sure that they sign in at the meeting.

2.4 Follow-Up Pre-Bid Meeting(s)

Follow-Up Meetings: In the event that a Vendor cannot attend the scheduled pre-bid meeting, or if a Vendor would like a follow up visit to the site, they may request a site visit by contacting **Ivan Ospinal** at **(954) 518-9020**. We urge all Vendors to attend the scheduled meeting, as a separate or follow-up meeting may not be afforded to the requester due to scheduling and availability of staff to assist with any additional meetings. In addition, if making a request for a separate or follow-up meeting, Vendors are urged to make these requests as early as possible.

2.5 Estimated Project Cost



\$200,000

2.6 Liquidated Damages

Liquidated damages for this project shall be **FIVE HUNDRED DOLLARS AND NO CENTS (\$500.00)** per day.

2.7 Grant/Federal Funding

Not applicable for this project.

2.8 Proposal Security/Bid Bond

A Proposal Security shall be required, only for bidders that have a total cumulative base proposal amount that exceeds \$200,000. Proposal Security shall be in the amount of 5% of the total cumulative base amount proposed.

2.9 Payment and Performance Bonds

Regardless of the awarded contract amount, two (2) separate bonds (Payment and Performance Bonds) are required, and both must be approved by the City. The penal sum stated in each bond shall be 100% of the contract price.

2.10 Permit, License, Impact or Inspection Fees

With the exception of the City related permit, license, impact or inspection fees (including the Building Department and Engineering Department Permit Fees), which will be waived for this project, the City does not anticipate any additional permit, license, impact or inspection fees for this project. Any related State or County fees, for the aforementioned permits, will be paid by the City.

In addition, the City shall cover the cost for any other permit fees related to external entities through the City's Owner's Contingency for this project, **therefore proposers should not include permit costs in their total proposal price.**

Furthermore, please note the City's average time for a **Vendor** to apply for and receive an approved permit is 30 days; delays in this timeline caused by the **Vendor's** failure to actively monitor the permit process and submit all required documentation in a timely manner, will count against the project's contractual completion period.

SECTION 3 - PURPOSE AND BACKGROUND

3.1 Purpose

The City of Pembroke Pines is seeking bids from qualified firms, hereinafter referred to as the Contractor, to install a 40-ton-air-cooled chiller with related mechanical and electrical upgrades at Studio 18, in accordance with the terms, conditions, and specifications contained in this solicitation.

The installation of a new chiller unit, including all necessary mechanical and electrical upgrades, is required to ensure uninterrupted operation and efficiency of Studio 18. The previous chiller is no longer available, as it is located in a building that was recently sold, making this replacement essential to maintain proper building functionality.

3.2 Background

Pembroke Pines, Florida, ranked as the eleventh largest city among the state's four hundred plus municipalities and the second largest in Broward County, maintains a welcoming small-town ambiance that resonates with its residents. Located conveniently in southwest Broward County, the city provides seamless access to major highways, employment centers, entertainment venues, parks, golf courses, and a diverse array of dining and shopping options.

With a population of approximately 170,000 residents spread across 32.68 square miles, Pembroke Pines is renowned as one of the best cities to live in America. The city boasts 28 superior parks, lush landscaping, and a distinctive South Florida charm that contributes to its natural beauty. Notably recognized as 2024's Best Place to Raise a Family in Florida, and 2024's Best City of Hispanic Entrepreneurs by WalletHub, Pembroke Pines also earned a place as the on Money Magazine's esteemed Best Places to Live list in 2014, as the sole Florida representative, ranking in at #32 in the nation.

Incorporated in 1960, Pembroke Pines is celebrated as a safe and desirable community, having received accolades such as the All-America City designation. The city's commitment to arts and culture, exceptional schools, diverse population, numerous parks, and forward-thinking approach in an ever-evolving world make it a standout destination.

Pembroke Pines is also the home to the largest municipal-run charter school system in the nation, serving over 6,000 students across five separate campuses. The City's award-winning charter school system is located in the Broward County School District, which is the sixth largest school district in the nation.

SECTION 4 - SCOPE OF WORK

4.1 Scope of Work

- Provide and install a new 40-ton air-cooled chiller (Trane CGAM040A2 or approved equal).
- Chiller shall include a minimum 5-year compressor parts warranty.
- Construct a new concrete foundation pad (per structural detail S-1.0) with a minimum of 4,000 PSI.
- Install Schedule 40 black steel chilled water piping with insulation as specified.
- Provide expansion tank, air separator, strainer, and bladder tank.
- Cap and abandon existing district chilled water piping as per plans.
- Connect to existing chilled water riser and AHUs.
- Provide factory startup, testing, and balancing.
- Remove existing 200A service meter; provide and install new 400A, 3-phase, 4-wire FPL-approved service.
- Install a new NEMA 4X outdoor-rated panelboard with feed-thru lugs and integrated surge protection.
- Install a new grounding system with two (2) 10-foot ground rods and associated copper conductors.
- Provide new disconnects, conduits, feeders, grounding, and bonding per NEC.
- Install a new GFCI weather-resistant duplex receptacle for the chiller controller.
- Coordinate with FPL for service shutdowns and transformer tie-in.
- Provide as-built drawings, panel schedules, and labeling.
- Provide with final payment all releases of liens, warranty, final project certification letter, inspection & test results, and as-built documentation.

4.2 Addition to Scope of Work - Permanent Fence Installation

- **Type:** Commercial six-gauge wire, green vinyl fence
- **Posts:**
 - 40-gauge galvanized posts
 - 2 ½ inch end posts

- 2 inch line posts
- **Rail:** 1 5/8 inch top rail
- **Bottom Wire:** 9-gauge wire
- **Gate:** 5 ft wide swing gate with box hinges
- **Frame:** 2 inch frame

4.3 General Requirements

- All work shall comply with the Florida Building Code (2023), NEC (2020), NFPA, and all local amendments.
- The contractor shall obtain and pay for all required permits, fees, and inspections. Only governmental fees will be covered by the vendor, and these costs will be reimbursed by the City of Pembroke Pines upon receipt of proof of payment. The contractor is responsible for scheduling all necessary inspections with the City's Building Department.
- Provide a minimum 1-year installation/workmanship warranty on all work and materials.
- Provide training for City staff on the proper operation and maintenance of the new systems.
- Provide complete operation and maintenance (O&M) manuals and as-built documentation.
- The contractor must call 811 Sunshine or the local utility notification service before any digging activities to ensure the safety and protection of underground utilities.

4.4 Supporting Documentation

Vendors submitting bids for this project must include as part of their submission requirements:

- Mechanical Schedule
- Schedule of Values

4.5 Post Award Requirements

If your company is awarded, the following documents will be required for processing and contract compliance.

- Manufacturer spec sheets
- Chilled/condenser water pump motor submittal
- System peak load profile/chiller manufacturer spec sheet
- AHRI certificate

4.6 Contractor Requirements

- Must be a licensed mechanical contractor in the State of Florida.
- Demonstrated experience with chiller installation projects of similar size and complexity.
- Compliance with all applicable building codes, standards, and regulations.
- Provide proof of insurance, including comprehensive general and auto liability, and workers' compensation.

4.7 Site Safety & Security

- **Temporary Fencing Requirement:** The contractor shall ensure that the construction site is securely fenced off during the entire duration of the project to ensure safety for the public and workers. The fencing must be in place prior to the commencement of construction activities.

4.8 Hurricane Preparedness

The contractor shall provide a hurricane preparedness plan and be responsible for implementing hurricane preparedness measures as necessary. This includes securing all materials and equipment, following city guidelines for storm preparation, and ensuring that the site is safe and compliant prior to any predicted severe weather events.

4.9 Working hours

The contractor must complete the project within the allowed timeframe of 60 calendar days. Normal working hours are Monday through Friday, 7 AM to 8 PM. If it is necessary to work on weekends, the contractor must reach out to the City of Pembroke Pines Project Manager for approval in advance.

4.10 Additional Compliance Notes

- All equipment shall be installed per the manufacturer's instructions, specifications, and recommendations for safe and efficient operations. Manufacturer operation and maintenance guides shall be issued to the building operator after successful completion of maintenance and/or preventative maintenance procedures training of the building operators.
- Upon completion, the HVAC systems must be fully commissioned by a certified commissioning authority. A preliminary commissioning report must be submitted within 90 days of the date of receipt of the certificate of occupancy.
- The City of Pembroke Pines has a standard trench backfill detail (#R-44) that the vendor will need to follow to meet engineering inspection standards. This detail calls for a trench depth of 24 inches.

SECTION 5 - PRICE PROPOSAL / BID TABLE

The vendor must provide their pricing electronically through the designated line items listed on the Bid Sheet/Pricing Table via the City's e-Procurement portal on OpenGov.

Vendor Notes: The bid tables includes a “Vendor Notes” column for any additional comments regarding the requested line item(s). A comment is preferred in the “Vendor Notes” column. If the vendor does not need to submit any comments, they may leave it blank or enter N/A or similar.

Payment & Performance Bonds: The table includes a section for the vendor to submit pricing for Payment & Performance Bonds. If the total cumulative base proposal amount does not exceed \$200,000 and a Payment and Performance Bond is not required, please enter “0” on the “If Applicable, Cost for Payment and Performance Bond” column for each line item.

Primary Responses: The initial Bid Table is for the primary responses so that the vendors can submit the requested goods and/or services.

Additional Responses: The second Bid Table allows for bidders to submit alternative options. Substitutions of brands or products must be submitted as an alternative for the City’s review and approval.

- A. To submit an alternative, please clearly identify any brand or product substitutions in the “Vendor Notes” column for the respective part.
- B. In addition, please upload any pertinent information relating to the alternative in the "Alternatives" section of the [SUBMITTAL DOCUMENTS](#).



PRIMARY RESPONSE

Line Item	Description	Quantity	Unit of Measure	Unit Cost	Total	Vendor Notes
1-1	Chiller Cost	1	Lump Sum			
1-2	Installation cost	1	Lump Sum			
1-3	Materials Costs	1	Lump Sum			
1-4	Concrete Slab Costs	1	Lump Sum			
1-5	Additional Considerations	1	Lump Sum			
TOTAL						

ALTERNATE RESPONSE

Line Item	Description	Quantity	Unit of Measure	Unit Cost	Total	Vendor Notes
1-1	Chiller Cost	1	Lump Sum			
1-2	Installation cost	1	Lump Sum			
1-3	Materials Costs	1	Lump Sum			
1-4	Concrete Slab Costs	1	Lump Sum			
1-5	Additional Considerations	1	Lump Sum			
TOTAL						

PAYMENT & PERFORMANCE BOND

Line Item	Description	Unit of Measure	Percentage
3-1	Cost to provide a Payment & Performance Bond for the project, in the form of a percent	Percent	



SECTION 6 - SUBMITTAL DOCUMENTS

Bids must be submitted electronically at <https://procurement.opengov.com/portal/pembrokepines> on or before **2:00 pm on Tuesday, December 9, 2025**. Please note vendors should be registered on OpenGov under the name of the organization that they are operating as and it should match the organization name on the documents that they are submitting and utilizing when responding to the solicitation. In addition, the vendor must complete the required documents in this section and provide any additional information requested throughout this solicitation. Any additional information requested in the solicitation should be scanned and uploaded. The City recommends for proposers to submit their proposals as soon as they are ready to do so. Please allow ample time to submit your proposals on the <https://procurement.opengov.com/portal/pembrokepines> website. Proposals may be modified or withdrawn prior to the deadline for submitting Proposals.

PLEASE DO NOT SUBMIT ANY PROPOSALS VIA MAIL, E-MAIL OR FAX.

Prospective proposers interested in responding to this solicitation are requested to provide all of the applicable information listed in this section. Submittals that do not respond completely to all of the requirements specified herein may be considered non-responsive and eliminated from the process. Brevity and clarity are encouraged.

1 CONFIRMATION TO BIND

1.1 I certify that I have read, understood and agree to the terms in this solicitation, and that I am authorized to submit this response on behalf of my company.*

Please confirm

*Response required

2 CERTIFICATION OF INSURANCE COMPLIANCE AND INTENT TO PROCURE REQUIRED COVERAGE

NOTE: Vendors are not required to purchase any additional insurance in order to submit a bid. However, they must certify that they either currently hold, or are able and willing to obtain, all required insurance coverages, endorsements, and limits prior to award and execution of the contract.

2.1 I certify that, if awarded this contract, I will be required to obtain and maintain all insurance policies as detailed in the INSURANCE REQUIREMENTS Section of this solicitation before any work may commence, and throughout the life of the contract.*

Please confirm

*Response required

2.2 Do you confirm that you will only use insurance carriers licensed to do business in the State of Florida and rated no less than “A” as to management, and no less than “Class VI” as to financial strength by A.M. Best, and that you understand all endorsements required (e.g., Additional Insured, Waiver of Subrogation, etc.) must be included?*

Yes

No



*Response required

2.3 Do you currently carry insurance policies that meet or exceed the minimum requirements outlined in the INSURANCE REQUIREMENTS section of this solicitation?*

Yes

No

*Response required

When equals "Yes"

2.3.1 Please upload your current certificate(s) of insurance that demonstrate compliance with the insurance requirements outlined in this solicitation.*

*Response required

When equals "No"

2.3.2 Please upload documentation showing that you have obtained a letter from your insurance broker or carrier, such as a Letter of Intent to Insure, Evidence of Insurability, or a Conditional Certificate of Insurance.*

Documentation should show that:

- You can obtain the required insurance.
- The limits and types of coverage will meet the INSURANCE REQUIREMENTS outlined in the solicitation.
- You will provide a COI upon contract award.

*Response required

When equals "No"

2.3.3 Please upload your current certificate(s) of insurance.*

*Response required

2.4 Do you believe you are exempt from one or more insurance requirements (e.g., Workers' Compensation)?*

Yes

No

*Response required

When equals "Yes"

2.4.1 Please upload written documentation requesting an exemption on your company letterhead, subject to City approval.*

*Response required

2.5 Do you plan on using subcontractors for this project?*

Yes



No

*Response required

When equals "Yes"

2.5.1 Do you acknowledge that all subcontractors must also carry the same insurance or be covered under your policy, and that proof of such coverage must be provided to the City?*

Yes

No

*Response required

3 REFERENCE # 1

The minimum experience for this project is **five (5) years**. Provide specific examples of similar experience conducting licensed work of equal or similar scope of work, preferably delivered by the proposed team members. A **minimum of 3** references should be from the last **five years** and should be capable of explaining and confirming your firm’s capacity to successfully complete the scope of work outlined herein. As part of the proposal evaluation process, the City may conduct an investigation of references, including a record check or consumer affairs complaints. Proposers’ submission of a proposal constitutes acknowledgment of the process and consent to investigate. The City is the sole judge in determining Proposers qualifications. In this section you will have the ability to enter information for 5 different references including their contact details and specific project information.

Please note that the City prefers references who are not current employees of the City of Pembroke Pines, as we generally do not contact our own employees for reference checks.

Proposers are advised to confirm that:

- A. Each reference provided by the Respondent has up to date contact persons and contact information;
- B. The contact person provided for each reference is someone who has personal knowledge of the Proposer's performance during the referenced project; and
- C. The contact person for each reference has been contacted by the Proposer regarding this specific bid submittal and such person confirmed their willingness to serve as a reference.

3.1 Reference Contact Information - Name of Firm, City, County or Agency*

*Response required

3.2 Reference Contact Information - Reference's Business Address*

*Response required

3.3 Reference Contact Information - Reference's Contact Name & Title*

*Response required



3.4 Reference Contact Information - Reference's E-mail Address*
*Response required

3.5 Reference Contact Information - Reference's Phone Number*
*Response required

3.6 Project Information - Was your firm the prime contractor for the listed project?*

Yes

No

*Response required

3.7 Project Information - Name of Contactor Performing the Work*
*Response required

3.8 Project Information - Name and location of the project*
*Response required

3.9 Project Information - Nature of the firm's responsibility on the project and work for which staff was responsible for*
*Response required

3.10 Project Information - Project Duration*
*Response required

3.11 Project Information - Completion (Anticipated) Date*
*Response required

3.12 Project Information - Size of Project*
*Response required

3.13 Project Information - Cost of Project*
*Response required

4 REFERENCE # 2

4.1 Reference Contact Information - Name of Firm, City, County or Agency*
*Response required

4.2 Reference Contact Information - Reference's Business Address*
*Response required

4.3 Reference Contact Information - Reference's Contact Name & Title*
*Response required

4.4 Reference Contact Information - Reference's E-mail Address*
*Response required

4.5 Reference Contact Information - Reference's Phone Number*
*Response required



- 4.6 Project Information - Was your firm the prime contractor for the listed project?*
- Yes
- No

*Response required

- 4.7 Project Information - Name of Contactor Performing the Work*
- *Response required

- 4.8 Project Information - Name and location of the project*
- *Response required

- 4.9 Project Information - Nature of the firm's responsibility on the project and work for which staff was responsible for*
- *Response required

- 4.10 Project Information - Project Duration*
- *Response required

- 4.11 Project Information - Completion (Anticipated) Date*
- *Response required

- 4.12 Project Information - Size of Project*
- *Response required

- 4.13 Project Information - Cost of Project*
- *Response required

5 REFERENCE # 3

- 5.1 Reference Contact Information - Name of Firm, City, County or Agency*
- *Response required

- 5.2 Reference Contact Information - Reference's Business Address*
- *Response required

- 5.3 Reference Contact Information - Reference's Contact Name & Title*
- *Response required

- 5.4 Reference Contact Information - Reference's E-mail Address*
- *Response required

- 5.5 Reference Contact Information - Reference's Phone Number*
- *Response required

- 5.6 Project Information - Was your firm the prime contractor for the listed project?*
- Yes
- No

*Response required



5.7 Project Information - Name of Contactor Performing the Work*
*Response required

5.8 Project Information - Name and location of the project*
*Response required

5.9 Project Information - Nature of the firm's responsibility on the project and work for which staff was responsible for*
*Response required

5.10 Project Information - Project Duration*
*Response required

5.11 Project Information - Completion (Anticipated) Date*
*Response required

5.12 Project Information - Size of Project*
*Response required

5.13 Project Information - Cost of Project*
*Response required

6 REFERENCE # 4

6.1 Reference Contact Information - Name of Firm, City, County or Agency

6.2 Reference Contact Information - Reference's Business Address

6.3 Reference Contact Information - Reference's Contact Name & Title

6.4 Reference Contact Information - Reference's E-mail Address

6.5 Reference Contact Information - Reference's Phone Number

6.6 Project Information - Was your firm the prime contractor for the listed project?

Yes

No

6.7 Project Information - Name of Contactor Performing the Work

6.8 Project Information - Name and location of the project

6.9 Project Information - Nature of the firm's responsibility on the project and work for which staff was responsible for

6.10 Project Information - Project Duration

6.11 Project Information - Completion (Anticipated) Date

6.12 Project Information - Size of Project

6.13 Project Information - Cost of Project

7 REFERENCE # 5



- 7.1 Reference Contact Information - Name of Firm, City, County or Agency
- 7.2 Reference Contact Information - Reference's Business Address
- 7.3 Reference Contact Information - Reference's Contact Name & Title
- 7.4 Reference Contact Information - Reference's E-mail Address
- 7.5 Reference Contact Information - Reference's Phone Number
- 7.6 Project Information - Was your firm the prime contractor for the listed project?
 Yes
 No
- 7.7 Project Information - Name of Contactor Performing the Work
- 7.8 Project Information - Name and location of the project
- 7.9 Project Information - Nature of the firm's responsibility on the project and work for which staff was responsible for
- 7.10 Project Information - Project Duration
- 7.11 Project Information - Completion (Anticipated) Date
- 7.12 Project Information - Size of Project
- 7.13 Project Information - Cost of Project

8 PROJECT DOCUMENTS

- 8.1 PROPOSERS BACKGROUND INFORMATION FORM*
 - a. Please download the attached document, complete all required fields, and upload the completed form here.
 - [Proposers Background Inform...](#)

*Response required

- 8.2 PROPOSAL SECURITY (BID BOND FORM OR CASHIER'S CHECK)
 - a. **In the event that your total cumulative base proposal amount exceeds \$200,000,** a Proposal Security shall be in an amount not less than of 5% of the total cumulative base amount proposed.
 - b. Therefore, proposal should be accompanied by a certified or cashier's check or by a Bid Bond made payable to the City of Pembroke Pines on an approved form, duly executed by the Proposer as principal and having as surety thereon a surety company acceptable to CITY and authorized to write such Bond under the laws of the State of Florida.
 - c. Contingency is not to be counted in the total amount the proposal security is based on.
 - d. Proposers must submit a scanned copy of their bid security (bid bond form or cashier's check) with their bid submittal through OpenGov.
 - e. Proposers should also submit their original bid security (bid bond form or cashier's check) at time of the bid due date, or they may be deemed as non-responsive.

- f. The original Bid Bond or Cashier's Check should be in a sealed envelope, plainly marked "**BID SECURITY - RE-25-07 New Chiller for Studio 18** and sent to the City of Pembroke Pines, City Clerk's Office, 4th Floor, 601 City Center Way, Pembroke Pines, Florida, 33025.
- g. Please see [SPECIAL TERMS & CONDITIONS](#) of this document for additional information.

9 SWORN STATEMENT ON PUBLIC ENTITY CRIMES UNDER FLORIDA STATUTES CHAPTER 287.133(3)(a)

9.1 SWORN STATEMENT ON PUBLIC ENTITY CRIMES FORM*

- a. Please download the attached document, complete all required fields, and upload the completed form here.

- [Sworn Statement on Public E...](#)

*Response required

9.2 Public Entity Crimes Status*

- Which option did you select on the Sworn Statement on Public Entity Crimes Form:
 - A) Neither the entity submitting this sworn statement, nor any officers, directors, executives, partners, shareholders, employees, members, or agents who are active in management of the entity, nor any affiliate of the entity have been charged with and convicted of a public entity crime subsequent to July 1, 1989.
 - B1) The entity submitting this sworn statement, or one or more of the officers, directors, executives, partners, shareholders, employees, members, or agents who are active in management of the entity, or an affiliate of the entity has been charged with and convicted of a public entity crime subsequent to July 1, 1989, AND There has been a proceeding concerning the conviction before a hearing officer of the State of Florida, Division of Administrative Hearings. The final order entered by the hearing officer did not place the person or affiliate on the convicted vendor list. (Please attach a copy of the final order.)
 - B2) The entity submitting this sworn statement, or one or more of the officers, directors, executives, partners, shareholders, employees, members, or agents who are active in management of the entity, or an affiliate of the entity has been charged with and convicted of a public entity crime subsequent to July 1, 1989, AND The person or affiliate was placed on the convicted vendor list. There has been a subsequent proceeding before a hearing officer of the State of Florida, Division of Administrative Hearings. The final order entered by the hearing

officer determined that it was in the public interest to remove the person or affiliate from the convicted vendor list. (Please attach a copy of the final order.)

- B3) The entity submitting this sworn statement, or one or more of the officers, directors, executives, partners, shareholders, employees, members, or agents who are active in management of the entity, or an affiliate of the entity has been charged with and convicted of a public entity crime subsequent to July 1, 1989, AND The person or affiliate has not been placed on the convicted vendor list. (Please describe any action taken by or pending with the Department of General Services.)

- A) No convictions.
- B1) Convicted, final order did not place on the convicted vendor list.
- B2) Convicted, listed, then removed.
- B3) Convicted, not listed, action pending.

*Response required

9.3 Did you select option B1 or B2 above?*

- Yes
- No

*Response required

When equals "Yes"

9.3.1 Please upload a copy of the final order issued by the hearing officer of the State of Florida, Division of Administrative Hearings.*

*Response required

9.4 Did you select option B3 above?*

- Yes
- No

*Response required

When equals "Yes"

9.4.1 Please describe any action taken by or pending with the Department of General Services.*

*Response required

10 EQUAL BENEFITS CERTIFICATION FOR DOMESTIC PARTNERS AND ALL MARRIED COUPLES

10.1 EQUAL BENEFITS CERTIFICATION FORM*

- a. Please download the attached document, complete all required fields, and upload the completed form here.

- [Equal Benefits Certificatio...](#)

*Response required

10.2 Equal Benefits Status*

- Which option did you select on the Equal Benefits Certification Form:
 - A. Contractor currently complies with the requirements of this section; or
 - B. Contractor will comply with the conditions of this section at the time of contract award; or
 - C. Contractor will not comply with the conditions of this section at the time of contract award: or
 - D. Contractor does not comply with the conditions of this section because of the following allowable exemption (Check only one box below):
 - 1. The Contractor does not provide benefits to employees' spouses in traditional marriages;
 - 2. The Contractor provides an employee the cash equivalent of benefits because the Contractor is unable to provide benefits to employees' Domestic Partners or spouses despite making reasonable efforts to provide them. To meet this exception, the Contractor shall provide a notarized affidavit that it has made reasonable efforts to provide such benefits. The affidavit shall state the efforts taken to provide such benefits and the amount of the cash equivalent. Cash equivalent means the amount of money paid to an employee with a Domestic Partner or spouse rather than providing benefits to the employee's Domestic Partner or spouse. The cash equivalent is equal to the employer's direct expense of providing benefits to an employee's spouse;
 - 3. The Contractor is a religious organization, association, society, or any non-profit charitable or educational institution or organization operated supervised or controlled by or in conjunction with a religious organization, association, or society;
 - 4. The Contractor is a governmental agency;

- A) Contractor currently complies.
- B) Will comply by contract award.
- C) Will not comply.
- D1) Does not comply due to an exemption: No spousal benefits for anyone.
- D2) Does not comply due to an exemption: Provides cash equivalent after trying.



D3) Does not comply due to an exemption: Religious or related nonprofit.

D4) Does not comply due to an exemption: Government agency.

*Response required

10.3 Did you select option D2 above?*

Yes

No

*Response required

When equals "Yes"

10.3.1 Please upload a notarized affidavit detailing the reasonable efforts made to provide benefits to employees' Domestic Partners or spouses, along with the amount of the cash equivalent provided.*

*Response required

11 DRUG-FREE WORKPLACE CERTIFICATION

11.1 VENDOR DRUG FREE WORKPLACE CERTIFICATION FORM*

a. Please download the attached document, complete all required fields, and upload the completed form here.

- [Vendor Drug-Free Workplace ...](#)

*Response required

11.2 Drug-Free Status*

Complies fully.

Does not comply.

*Response required

12 STANDARD DOCUMENTS

The following documents are standard documents that the City generally requires for every solicitation. As a result, we recommend vendors to keep these documents updated and readily available so that they can be easily uploaded for each project that the vendor would like to participate in. In the event that the City does not have one of the forms or documents listed below for your company, the City may reach out to your company after the bid has closed to obtain the document(s).

12.1 NON-COLLUSIVE AFFIDAVIT*

a. Please download the attached document, complete all required fields, and upload the completed form here.

12.2 SCRUTINIZED COMPANY CERTIFICATION*

a. Please download the attached document, complete all required fields, and upload the completed form here.

- [Scrutinized Company Certifi...](#)

*Response required

12.3 E-VERIFY SYSTEM CERTIFICATION*

a. Please download the attached document, complete all required fields, and upload the completed form here.

b. Effective January 1, 2021, pursuant to Section 448.095, Florida Statutes, the City may not enter into a contract with a vendor/contractor/subcontractor unless that vendor/contractor/subcontractor is registered with and uses the E-Verify system administered by the U.S. Department of Homeland Security (“DHS”).

c. Contractor shall also require all subcontractors to provide an affidavit attesting that the subcontractor does not employ, contract with, or subcontract with, an unauthorized alien. The Contractor shall maintain a copy of such affidavit for the duration of the contract.

- [E-Verify System Certificati...](#)

*Response required

12.4 HUMAN TRAFFICKING AFFIDAVIT*

a. Please download the attached document, complete all required fields, and upload the completed form here.

- [Human Trafficking Affidavit...](#)

*Response required

13 VENDOR REGISTRATION

13.1 Do you currently have a City of Pembroke Pines Vendor Number registered in the PaymentWorks System?*

- The City of Pembroke Pines utilizes OpenGov as its e-Procurement platform for solicitation and bid submission purposes. However, please be advised that **vendor registration for onboarding and processing payments is handled separately** through the City's Accounts Payable Division using **PaymentWorks**, a secure online vendor management platform.
- All vendors that will be submitting invoices and requiring payments from the City are required to register on the PaymentWorks platform. If the vendor is not currently

registered with the City via PaymentWorks and does not have a Vendor Number, the City will have to invite the vendor to register.

- For formal solicitations such as this project, the Procurement Department will send PaymentWorks registration invitations to vendor(s) who are under active consideration for award. Please be aware that not all vendors who submit proposals will receive an invitation, in order to manage system usage and avoid onboarding vendors who are unlikely to receive payments from the City.
- Invitations will typically be sent to the contact listed on the submitted Vendor Information Form.

Yes

No

*Response required

When equals "Yes"

13.1.1 What is your Vendor Number?*

*Response required

13.2 VENDOR INFORMATION FORM*

- a. Please download the attached document, complete all required fields, and upload the completed form here.

- [Vendor Information Form.pdf](#)

*Response required

13.3 FORM W-9 (REVISED MARCH 2024)*

- a. Please download the attached document, complete all required fields, and upload the completed form here.
- b. Note - Please use the March 2024 version of the form as previously dated versions of this form may delay the processing of any payments to the selected vendor.

- [Form W-9 \(Rev March 2024\).pdf](#)

*Response required

14 OPTIONAL DOCUMENTATION

14.1 TRADE SECRETS

- a. The Proposer's response to this solicitation is a public record pursuant to Florida law, which is subject to disclosure by the City under the State of Florida Public Records Law, Florida Statutes Chapter 119.07 ("Public Records Law"). The City shall permit public access to all documents, papers, letters or other material submitted in

connection with this solicitation and the Contract to be executed for this solicitation, subject to the provisions of Chapter 119.07 of the Florida Statutes.

- b. Any language contained in the Proposer's response to the solicitation purporting to require confidentiality of any portion of the Proposer's response to the solicitation, except to the extent that certain information is in the City's opinion a Trade Secret pursuant to Florida law, shall be void. If a Proposer submits any documents or other information to the City which the Proposer claims is Trade Secret information and exempt from Florida Statutes Chapter 119.07 ("Public Records Laws"), the Proposer shall clearly designate that it is a Trade Secret and that it is asserting that the document or information is exempt. The Proposer must specifically identify the exemption being claimed under Florida Statutes 119.07. The City shall be the final arbiter of whether any information contained in the Proposer's response to the solicitation constitutes a Trade Secret.
- c. EXCEPT FOR CLEARLY MARKED PORTIONS THAT ARE BONA FIDE TRADE SECRETS PURSUANT TO FLORIDA LAW, DO NOT MARK YOUR RESPONSE TO THE SOLICITATION AS PROPRIETARY OR CONFIDENTIAL. DO NOT MARK YOUR RESPONSE TO THE SOLICITATION OR ANY PART THEREOF AS COPYRIGHTED. ALL DOCUMENTS THAT THE FIRM PURPORTS TO BE CONFIDENTIAL, PROPRIETARY OR A TRADE SECRET SHALL BE UPLOADED TO THE OPENGOV WEBSITE AS A SEPARATE ATTACHMENT, IN THIS SECTION, CLEARLY IDENTIFYING THE EXEMPTION BEING CLAIMED UNDER FLORIDA STATUTES 119.07.
- d. The city's determination of whether an exemption applies shall be final, and the proposer agrees to defend, indemnify, and hold harmless the city and the city's officers, employees, and agent, against any loss or damages incurred by any person or entity as a result of the city's treatment of records as public records.

14.2 FINANCIAL STATEMENTS

- a. The City is **NOT** requesting the vendor to submit any financial statements for this project and prefers if the vendor does not submit financial statements. In addition, if the City needs a copy of the vendor's financial statements, the City can contact the vendor after the bid due date to request those documents. However, if the vendor does submit the financial statements, they should be uploaded in this section.
- b. Any claim of confidentiality on financial statements must be asserted at the time of submittal. The firm must identify the specific statute that authorizes the exemption from the Public Records Law. Please note that the financial statement exemption

provided for in Section 119.071(1)c, Florida Statutes only applies to submittals in response to a solicitation for a “public works” project.

14.3 ALTERNATIVES

- a. If you are submitting an alternative product, please upload any related information in this section (such as specification sheets, etc.).
- b. In addition, pursuant to the “**Brand Names**” Section included in the [GENERAL TERMS AND CONDITIONS](#) Section if and wherever in the specifications a brand name, make, name of manufacturer, trade name, or vendor catalog number is mentioned, it is for the purpose of establishing a grade or quality of material only. Since the City does not wish to rule out other competition and equal brands or makes, the phrase “OR EQUAL” is added. However, if a product other than that specified is bid, Proposers shall indicate on their proposal and clearly state the proposed substitution and deviation. It is the vendor’s responsibility to provide any necessary documentation and samples within their bid submittal to prove that the product is equal to that specified. Such samples are to be furnished before the date of bid opening, unless otherwise specified. Additional evidence in the form of documentation and samples may be requested if the proposed brand is other than that specified. The City retains the right to determine if the proposed brand shall be considered as an approved equivalent or not.

14.4 ADDITIONAL INFORMATION

- a. Please provide any additional information that you deem necessary to complete your proposal in this section, if it has not been requested in another section.

14.5 PROFESSIONAL LICENSES

- a. If applicable, please upload any professional licenses that may be required to perform the services outlined in the solicitation. The following licensing requirements shall apply when the applicable Florida statute mandates specific licensing for Contractors engaged in the type of work covered by this solicitation.
 1. State of Florida, Department of Professional Regulation, Construction Industries Licensing Board and licensed by other federal, state, regional, county or municipal agencies having jurisdiction over the specified construction work.
 2. Said licenses shall be in the Firm's name as it appears on the OpenGov registration and as appropriately registered with the applicable licensing entity. Proposer shall supply appropriate license numbers, with expiration dates, as part of their bid. Failure to hold and provide proof of proper licensing, certification and registration may be grounds for rejection of the bid.



- 3. Subcontractors contracted by the Prime Contractor shall be licensed in their respective fields to obtain construction permits as necessary. Said licenses must be in the name of the subcontractor.

15 VENDOR CLASSIFICATION

15.1 Is your firm a Local Pembroke Pines Vendor (LPPV) and Local Broward County Vendor (LBCV)?*

- a. The evaluation of competitive bids is subject to section 35.36 of the City’s Procurement Procedures which, except where contrary to federal and state law, or any other funding source requirements, provides that preference be given to local businesses. To satisfy this requirement, the vendor shall affirm in writing its compliance with either of the following objective criteria as of the bid or proposal submission date stated in the solicitation. A local business shall be defined as:

- 1. **"Local Pembroke Pines Vendor"** shall mean a business entity which has maintained a permanent place of business with full-time employees within the City limits for a minimum of one (1) year prior to the date of issuance of a bid or proposal solicitation. The permanent place of business may not be a post office box. The business location must actually distribute goods or services from that location. In addition, the business must have a current business tax receipt from the City of Pembroke Pines, **OR**;
- 2. **"Local Broward County Vendor"** shall mean or business entity which has maintained a permanent place of business with full-time employees within the Broward County limits for a minimum of one (1) year prior to the date of issuance of a bid or proposal solicitation. The permanent place of business may not be a post office box. The business location must actually distribute goods or services from that location. In addition, the business must have a current business tax receipt from the Broward County or the city within Broward County where the business resides.

- b. A preference of five percent (5%) of the total evaluation point, or five percent (5%) of the total price, shall be given to the Local Pembroke Pines Vendor(s); A preference of two and a half percent (2.5%) of the total evaluation point for local, or two and a half percent (2.5%) of the total price, shall be given to the Local Broward County Vendor(s).

- Yes
- No

*Response required

When equals "Yes"

15.1.1 Please indicate your Local Vendor Status*

Local Pembroke Pines Vendor (LPPV)

Local Broward County Vendor (LBCV)

*Response required

When equals "Yes"

15.1.2 Local Vendor Preference Certification*

1. Please download the attached document, complete all required fields, and upload the completed form here.

- [Local Vendor Preference Cer...](#)

*Response required

When equals "Yes"

15.1.3 Local Business Tax Receipts*

1. If claiming Local Vendor Preference, please upload any previous business tax receipts to indicate that the business entity has maintained a permanent place of business for a minimum of one (1) year.

*Response required

15.2 Is your firm a Veteran Owned Small Business (VOSB)?*

- a. The evaluation of competitive bids is subject to section 35.37 of the City's Procurement Procedures which, except where contrary to federal and state law, or any other funding source requirements, provides that preference be given to veteran owned small businesses. To satisfy this requirement, the vendor shall affirm in writing its compliance with the following objective criteria as of the bid or proposal submission date stated in the solicitation.
- b. A preference of two and a half percent (2.5%) of the total evaluation point, or two and a half percent (2.5%) of the total price, shall be given to the Veteran Owned Small Business (VOSB).

Yes

No

*Response required

When equals "Yes"

15.2.1 Upload the "Determination Letter" from the United States Department of Veteran Affairs Center notifying the business that they have been approved as a Veteran Owned Small Business (VOSB)

When equals "Yes"



15.2.2 Upload Veteran Owned Small Business Certification(s) from any relevant agency(ies)

15.3 Is your firm a Minority-Owned Business Enterprise (MBE)?*

Yes

No

*Response required

When equals "Yes"

15.3.1 Please indicate the classification of your Minority-Owned Business Enterprise (MBE)*

Select all that apply

African-American MBE

Asian-American MBE

Hispanic-American MBE

Native-American MBE

Other option not listed above

*Response required

When equals "Yes"

15.3.2 MBE Certification Documentation*

1. Upload your MBE Certification Documentation here, preferably with the State of Florida's Office of Supplier Diversity. If you have multiple MBE certifications, please combine them into one (1) document and upload.

*Response required

15.4 Is your firm a Woman-Owned Business Enterprise (WBE)?*

Yes

No

*Response required

When equals "Yes"

15.4.1 WMBE Certification Documentation*

1. Upload your WMBE Certification Documentation here, preferably with the State of Florida's Office of Supplier Diversity. If you have multiple WMBE certifications, please combine them into one (1) document and upload.

*Response required

15.5 Is your firm a HubZone Business / Labor Surplus Area Firm?*

Yes

No



*Response required

When equals "Yes"

- 15.5.1 HubZone Business / Labor Surplus Area Firm Certification Documentation*
1. Upload your HubZone Business / Labor Surplus Area Firm Certification Documentation, preferably with the U.S. Small Business Administration (SBA). If you have multiple certifications, please combine them into one (1) document and upload.

*Response required

15.6 Is your firm a Broward County Small Business Enterprise (SBE)?*

- Yes
 No

*Response required

When equals "Yes"

- 15.6.1 SBE Certification Documentation*
1. Upload your SBE Certification Documentation from Broward County's Office of Economic and Small Business Development (OESBD). If you have multiple certifications, please combine them into one (1) document and upload.

*Response required

15.7 Is your firm a Broward County Business Enterprise (CBE)?*

- Yes
 No

*Response required

When equals "Yes"

- 15.7.1 CBE Certification Documentation*
1. Upload your CBE Certification Documentation from Broward County's Office of Economic and Small Business Development (OESBD). If you have multiple certifications, please combine them into one (1) document and upload.

*Response required

15.8 Is your firm a Broward County Disadvantaged Business Enterprise (DBE)?*

- Yes
 No

*Response required

When equals "Yes"

15.8.1 DBE Certification Documentation*

1. Upload your DBE Certification Documentation from Broward County's Office of Economic and Small Business Development (OESBD). If you have multiple certifications, please combine them into one (1) document and upload.

*Response required

15.9 Does your firm have a Vendor Classification that was not listed above?*

Yes

No

*Response required

When equals "Yes"

15.9.1 Other Vendor Classification Certification Documentation*

1. Upload your other Certification Documentation here. If you have multiple certifications, please combine them into one (1) document and upload.

*Response required

16 Supporting Documentation

Documents requested per Section 4.3 of the scope of work.

16.1 Please upload Schedule of Values and Mechanical Schedule*

*Response required

17 Post Award Requirements

This is an optional section per section 4.4 of the scope of work.

17.1 Optional - Please upload the requested documents below if available at time of bid. If your company is awarded, the following documents will be required for processing and contract compliance.

- Manufacturer spec sheets
- Chilled/condenser water pump motor submittal
- System peak load profile/chiller manufacturer spec sheet
- AHRI certificate

SECTION 7 - EVALUATION OF PROPOSALS & PROCESS SELECTION

7.1 Qualifying & Selecting Firms

- A. Staff will evaluate all responsive proposals received from proposers who meet or exceed the bid requirements contained in the solicitation. Evaluations shall be based upon the information and references contained in the proposals as submitted.
- B. Staff will make a recommendation to the City Commission for award of contract.
- C. The contract shall be awarded to the most responsive/responsible bidder whose bid is determined to be the most advantageous to the City taking into consideration the evaluation criteria.

SECTION 8 - INSURANCE REQUIREMENTS

8.1 Indemnification for Design Professionals and Construction Contracts

The Vendor shall indemnify and hold harmless the CITY, its officers and employees from any and all liability, losses or damages, including reasonable attorneys' fees and costs of defense, which the CITY, its officers and employees, may incur as a result of claims, demands, suits, causes of actions or proceedings of any kind or nature to the extent such claims are caused by negligence, recklessness, or intentional wrongful conduct of the Vendor and other persons employed or utilized by Vendor during performance of this Agreement. The Vendor shall pay all claims and losses in connection therewith and shall investigate and defend all claims, suits or actions of any kind or nature in the name of the CITY, where applicable, including appellate proceedings, and shall pay all costs, judgments, and attorneys' fees which may issue thereon. The Vendor expressly understands and agrees that any insurance protection required by this Agreement or otherwise provided by the Vendor shall in no way limit the responsibility to indemnify, keep and save harmless and defend the CITY or its officers, employees, agents and instrumentalities as herein provided.

8.2 Insurance Coverage

- A. **Vendor** shall not commence work under this Agreement until it has obtained all insurance required under this paragraph and such insurance has been approved by the Risk Manager of the CITY nor shall the **Vendor** allow any subcontractor to commence work on any subcontract until all similar such insurance required of the subcontractor has been obtained and similarly approved.
- B. Certificates of Insurance, reflecting evidence of the required insurance, shall be filed with the CITY's Risk Manager prior to the commencement of this Agreement. Policies shall be issued by companies authorized to do business under the laws of the State of Florida. The insurance company shall be rated no less than "A" as to management, and no less than "Class VI" as to financial strength according to the latest edition of Best's Insurance Guide published by A.M. Best Company.
- C. Certificates of Insurance shall provide for thirty (30) days' prior written notice to the CITY in case of cancellation or material changes in the policy limits or coverage states. If the carrier cannot provide thirty (30) days' notice of cancellation, either the **Vendor** or their Insurance Broker must agree to provide notice.
- D. Insurance shall be in force until all obligations required to be fulfilled under the terms of the Agreement are satisfactorily completed as evidenced by the formal acceptance by the CITY. In the event the insurance certificate provided indicates that the insurance shall terminate and lapse during the period of this Agreement, the **Vendor** shall furnish, at least forty-five (45) days prior to the expiration of the date of such insurance, a renewed certificate of insurance as proof that equal and like coverage for the balance of the period of the



Agreement and extension thereunder is in effect. The **Vendor** shall neither commence nor continue to provide any services pursuant to this Agreement unless all required insurance remains in full force and effect. **Vendor** shall be liable to CITY for any lapses in service resulting from a gap in insurance coverage.

- E. **Vendor** shall be required to obtain all applicable insurance coverage, as indicated in the sections below, prior to commencing any work pursuant to this Agreement.

8.3 Comprehensive General Liability Insurance

Comprehensive General Liability Insurance written on an occurrence basis including, but not limited to: coverage for bodily injury and property damage, personal & advertising injury, products & completed operations, and contractual liability. Coverage must be written on an occurrence basis, with limits of liability no less than:

- A. Each Occurrence Limit - \$1,000,000
- B. Fire Damage Limit (Damage to rented premises) - \$100,000
- C. Personal & Advertising Injury Limit - \$1,000,000
- D. General Aggregate Limit - \$2,000,000
- E. Products & Completed Operations Aggregate Limit - \$2,000,000

Products & Completed Operations Coverage shall be maintained for the later of three (3) years after the delivery of goods/services or final payment under the Agreement. *(For Construction projects: Increase to ten (10) years and include a Designated Construction Project(s) General Aggregate Limit)*

The City of Pembroke Pines must be shown as an additional insured with respect to this coverage. The CITY's additional insured status shall extend to any coverage beyond the minimum limits of liability found herein.

8.4 Workers' Compensation and Employers' Liability Insurance

Workers' Compensation and Employers' Liability Insurance covering all employees, and/or volunteers of the **Vendor** engaged in the performance of the scope of work associated with this Agreement. In the case any work is sublet, the **Vendor** shall require the subcontractors similarly to provide Workers' Compensation Insurance for all the latter's employees unless such employees are covered by the protection afforded by the **Vendor** Coverage for the **Vendor** and all subcontractors shall be in accordance with applicable state and/or federal laws that may apply to Workers' Compensation Insurance with limits of liability no less than:

- A. Workers' Compensation: Coverage A – Statutory
- B. Employers Liability: Coverage B

\$500,000 Each Accident



\$500,000 Disease – Policy Limit

\$500,000 Disease – Each Employee

If **Vendor** claims to be exempt from this requirement, **Vendor** shall provide CITY proof of such exemption along with a written request for CITY to exempt **Vendor**, written on **Vendor** letterhead.

8.5 Comprehensive Auto Liability Insurance

Comprehensive Auto Liability Insurance covering all owned, non-owned and hired vehicles used in connection with the performance of work under this Agreement, with a combined single limit of liability for bodily injury and property damage no less than:

- A. Any Auto (Symbol 1)
Combined Single Limit (Each Accident) - \$1,000,000
- B. Hired Autos (Symbol 8)
Combined Single Limit (Each Accident) - \$1,000,000
- C. Non-Owned Autos (Symbol 9)
Combined Single Limit (Each Accident) - \$1,000,000

If work under this Agreement includes transportation of hazardous materials, policy shall include pollution liability coverage equivalent to that provided by the latest version of the ISO pollution liability broadened endorsement for auto and the latest version of the ISO Motor Carrier Act endorsement, equivalents or broader language.

If **Vendor** requests reduced limits under a Personal Auto Liability Policy and it is agreed to by the CITY, coverage shall include Bodily Injury limits of \$100,000 per person/\$300,000 per occurrence and Property Damage limits of \$300,000 per occurrence.

8.6 Umbrella/Excess Liability Insurance

Umbrella/Excess Liability Insurance in the amount of **\$2,000,000** as determined appropriate by the CITY depending on the type of job and exposures contemplated. Coverage must be follow form of the General Liability, Auto Liability and Employer's Liability. This coverage shall be maintained for a period of no less than the later of three (3) years after the delivery of goods/services or final payment pursuant to this Agreement.

The City of Pembroke Pines must be shown as an additional insured with respect to this coverage. The CITY's additional insured status shall extend to any coverage beyond the minimum limits of liability found herein.

8.7 Required Endorsements

- A. The City of Pembroke Pines shall be named as an Additional Insured on each of the Liability Policies required herein.
- B. Waiver of all Rights of Subrogation against the CITY.

- C. Thirty (30) Day Notice of Cancellation or Non-Renewal to the CITY.
- D. **Vendor**'s policies shall be Primary & Non-Contributory.
- E. All policies shall contain a "severability of interest" or "cross liability" clause without obligation for premium payment of the CITY.
- F. The City of Pembroke Pines shall be named as a Loss Payee on all Property and/or Inland Marine Policies as their interest may appear.

8.8 Additional Requirements

- A. Any and all insurance required of the **Vendor** pursuant to this Agreement must also be required by any subcontractor in the same limits and with all requirements as provided herein, including naming the CITY as an additional insured, in any work that is subcontracted unless such subcontractor is covered by the protection afforded by the **Vendor** and provided proof of such coverage is provided to CITY. The **Vendor** and any subcontractors shall maintain such policies during the term of this Agreement.
- B. The CITY reserves the right to require any other additional types of insurance coverage and/or higher limits of liability it deems necessary based on the nature of work being performed under this Agreement.
- C. The insurance requirements specified in this Agreement are minimum requirements and in no way reduce any liability the **Vendor** has assumed in the indemnification/hold harmless section(s) of this Agreement.

SECTION 9 - GENERAL TERMS AND CONDITIONS

9.1 EXAMINATION OF CONTRACT DOCUMENTS

Before submitting a Proposal, each Proposer should:

- A. consider federal, state and local laws, ordinances, rules and regulations that may in any manner affect cost or performance of the work,
- B. study and carefully correlate the Proposer's observations with the Proposal Documents; and
- C. notify the Purchasing Manager of all conflicts, errors and discrepancies, if any, in the Proposal Documents.

The Proposer, by and through the submission of a Proposal, agrees that Proposer shall be held responsible for having familiarized themselves with the nature and extent of the work and any local conditions that may affect the work to be done and the services, equipment, materials, parts and labor required.

9.2 CONFLICT OF INSTRUCTIONS

If a conflict exists between the General Conditions and Instructions stated herein and specific conditions and instructions contained in specifications, the specifications shall govern.

9.3 ADDENDA or ADDENDUM

A formal solicitation may require an Addendum to be issued. An addendum in some way may clarify, correct or change the original solicitation (i.e. due date/time, specifications, terms, conditions, line item).

Bidders must register for an account on the City's e-Procurement Portal, hosted by OpenGov. Once the bidder has completed registration, they will receive addenda notifications via email by clicking "Follow" on this project. Ultimately, it is the sole responsibility of each bidder to periodically check the site for any addenda at <https://procurement.opengov.com/portal/pembrokepines>.

Vendors are cautioned not to consider verbal modifications to the solicitation, as the addendum issued through OpenGov will be the only official method whereby changes will be made.

9.4 INTERPRETATIONS AND QUESTIONS

If the Proposer is in doubt as to the meaning of any of the Proposal Documents, is of the opinion that the Conditions and Specifications contain errors or contradictions or reflect omissions, or has any question concerning the conditions and specifications, the Proposer shall submit a question for interpretation or clarification.

The City requires all questions relating to the solicitation to be submitted through the "Question & Answer" tab, for the specific project, on the City's e-Procurement Portal, located at <https://procurement.opengov.com/portal/pembrokepines>. Questions and inquiries must be received by the "Question Due Date" stated in the solicitation. Questions received after the "Question Due



Date” shall not be answered. Interpretations or clarifications in response to such questions will be issued via OpenGov. Bidders may also click “Follow” on this solicitation to receive an e-mail notification(s) when answers are posted. It is the responsibility of the bidder to check the website for answers to inquiries. The issuance of a response via OpenGov is considered an Addendum and shall be the only official method whereby such an interpretation or clarification will be made.

OpenGov Support is also available to assist proposers with submitting their proposal and to ensure that proposers are submitting their proposals correctly. Proposers should ensure that they contact OpenGov support, with ample time before the bid closing date and time, via one of the following methods:

- A. Chat (preferred method): Click the button in the lower right-hand corner of the portal when logged in.
- B. E-mail: support@opengov.com
- C. Phone: 1 (605) 336-7167
- D. <https://opengov.my.site.com/support/s/contactsupport>

For all other questions related to this solicitation, please contact the Procurement Department at purchasing@ppines.com.

9.5 RULES, REGULATIONS, LAWS, ORDINANCES and LICENSES

The awarded **Vendor** shall observe and obey all laws, ordinances, rules, and regulations of the federal, state, and CITY, which may be applicable to the service being provided. The awarded firm shall have or be responsible for obtaining all necessary permits or licenses required, if necessary, in order to provide this service.

Proposer warrants by submittal that prices quoted here are in conformity with the latest federal price guidelines, if any.

9.6 WARRANTIES FOR USAGE

Whenever a bid is sought, seeking a source of supply for a specified time for materials or service, the quantities or usage shown are estimated only. No guarantee or warranty is given or implied by the City as to the total amount that may or may not be purchased from any resulting contracts. These quantities are for proposer’s information only and will be used for tabulation and presentation of bid.

9.7 BRAND NAMES

If and wherever in the specifications a brand name, make, name of manufacturer, trade name, or vendor catalog number is mentioned, it is for the purpose of establishing a grade or quality of material only. Since the City does not wish to rule out other competition and equal brands or makes, the phrase “OR EQUAL” is added. However, if a product other than that specified is bid, Proposers shall indicate on their proposal and clearly state the proposed substitution and deviation. It is the **Vendor’s responsibility** to provide any necessary documentation and samples within their bid submittal to prove that the product is equal to that specified. Such samples are to be furnished before the date of bid opening, unless otherwise specified. Additional evidence in the form of



documentation and samples may be requested if the proposed brand is other than that specified. The City retains the right to determine if the proposed brand shall be considered as an approved equivalent or not.

9.8 QUALITY

All materials used for the manufacture or construction of any supplies, materials, or equipment covered by this bid shall be new, the latest model, of the best quality, and highest grade workmanship, unless otherwise noted.

9.9 SAMPLES

Samples, when requested, must be furnished before, or at the bid opening, unless otherwise specified, and delivered free of expense to the City and if not used in testing or destroyed, will upon request within thirty (30) days of bid award be returned at the proposer's expense.

9.10 ESTIMATED QUANTITIES

No guarantee is expressed or implied as to the total quantity of commodities/services to be purchased pursuant to this solicitation. Estimated quantities will be used for comparison and ranking purposes only. The City is not obligated to contract for a given amount of commodities/services subsequent to the award of this solicitation. The City reserves the right to issue separate purchase orders as needed, issue a blanket purchase order, and release partial quantities, or any combination of the preceding as deemed necessary by the City.

9.11 DEVELOPMENT COSTS

Neither the City nor its representatives shall be liable for any expenses incurred in connection with the preparation, submission or presentation of a Bid in response to this solicitation. All information in the Bid shall be provided at no cost to the City.

9.12 PRICING

Prices should be stated in units of quantity specified in the bidding specifications. In case of discrepancy in computing the amount of the bid, the unit prices quoted will govern.

Proposer warrants by virtue of bidding that prices, terms, and conditions quoted in his bid will be firm for acceptance for a period of ninety (90) days from date of bid opening unless otherwise stated by the City or proposer.

9.13 DELIVERY POINT

All items shall be delivered F.O.B. destination, and delivery cost and charges included in the bid price. Failure to do so may be cause for rejection of bid.

9.14 TAX EXEMPT STATUS

The City is exempt from Florida Sales and Federal Excise taxes on direct purchase of tangible property.

9.15 CONTRACT TIME

By virtue of the submission of the Proposal, Proposer agrees and fully understands that the completion time of the work of the Contract is an essential and material condition of the Contract and that time is of the essence. The Successful Proposer agrees that all work shall be prosecuted regularly, diligently and uninterrupted at such rate of progress as will ensure full completion thereof within the time specified. Failure to complete the work within the time period specified shall be considered a default.

In addition, time will be of the essence for any orders placed as a result of this bid. Purchaser reserves the right to cancel such orders, or part thereof, without obligation if delivery is not made at the time(s) or place(s) specified.

9.16 COPYRIGHT OR PATENT RIGHTS

Proposer warrants that there have been no violations of copyrights or patent rights in manufacturing, producing, or selling other goods shipped or ordered as a result of this bid, and seller agrees to hold the purchaser harmless from any and all liability, loss or expense occasioned by such violation.

9.17 ANTI-TRUST VIOLATIONS

Pursuant to Section 287.137, Florida Statutes, as may be amended, a person or an affiliate who has been placed on the antitrust violator vendor list following a conviction or being held civilly liable for an antitrust violation may not submit a bid, proposal, or reply for any new contract to provide any goods or services to a public entity; may not submit a bid, proposal, or reply for a new contract with a public entity for the construction or repair of a public building or public work; may not submit a bid, proposal, or reply on new leases of real property to a public entity; may not be awarded or perform work as a contractor, supplier, subcontractor, or consultant under a new contract with a public entity; and may not transact new business with a public entity.

9.18 PUBLIC ENTITY CRIMES

Pursuant to Sec. 287.133(2)(a), Fla. Stat., a person or affiliate who has been placed on the convicted vendor list following a conviction for a public entity crime or who has been placed on the discriminatory vendor list may not submit a bid on a contract to provide any goods or services to a public entity, may not submit a bid on a contract with a public entity for the construction or repair of a public building or public work, may not submit bids on leases of real property to a public entity, may not be awarded or perform work as a contractor, supplier, subcontractor, or consultant under a contract with any public entity, and may not transact business with any public entity in excess of the threshold amount provided in Section 287.017, for CATEGORY TWO for a period of 36 months from the date of being placed on the convicted vendor list.

Pursuant to Sec. 287.134(2)(b), Fla. Stat., a public entity may not accept any bid, proposals, or replies from, award any contract to, or transact any business with any entity or affiliate on the discriminatory vendor list for a period of 36 months following the date that entity or affiliate was placed on the discriminatory vendor list unless that entity or affiliate has been removed from the list. A public entity that was transacting business with an entity at the time of the discrimination resulting in that entity being placed on the discriminatory vendor list may not accept any bid, proposal, or reply from, award any contract to, or transact any business with any other entity who is under the



same, or substantially the same, control as the entity whose name appears on the discriminatory vendor list so long as that entity's name appears on the discriminatory vendor list.

The Sworn Statement of Public Entity Crime Affidavit Form, in the Submittal Documents section on the OpenGov portal for this solicitation, includes documentation that shall be executed by an individual authorized to bind the Proposer. The Proposer further understands and accepts that any contract issued as a result of this solicitation shall be either voidable or subject to immediate termination by the City. In the event there is any misrepresentation or lack of compliance with the mandates of Section 287.133 or Section 287.134, respectively, Florida Statutes. The City in the event in such termination, shall not incur any liability to the Proposer for any goods, services or materials furnished.

9.19 CONFLICT OF INTEREST

The award of any contract hereunder is subject to the provisions of Chapter 112, Florida Statutes. Proposers must disclose with their Proposal the name of any officer, director, partner, proprietor, associate or agent who is also an officer or employee of CITY or any of its agencies. Further, all Proposers must disclose the name of any officer or employee of CITY who owns, directly or indirectly, an interest of five percent (5%) or more in the Proposer 's firm or any of its branches or affiliate companies.

9.20 FACILITIES

The City reserves the right to inspect the Proposer's facilities at any time with prior notice.

9.21 ENVIRONMENTAL REGULATIONS

CITY reserves the right to consider Proposer's history of citations and/or violations of environmental regulations in determining a Proposer's responsibility, and further reserves the right to declare a Proposer not responsible if the history of violations warrant such determination. Proposer shall submit with the Proposal, a complete history of all citations and/or violations, notices and dispositions thereof. The non-submission of any such documentation shall be deemed to be an affirmation by the Proposer that there are no citations or violations. Proposer shall notify CITY immediately of notice of any citation or violation that Proposer may receive after the Proposal opening date and during the time of performance of any contract awarded to Proposers.

9.22 SIGNATURE REQUIRED

All proposals must be signed with the firm name and by an officer or employee having authority to bind the company or firm by his signature. FAILURE TO PROPERLY SIGN PROPOSAL SHALL INVALIDATE SAME, AND IT MAY NOT BE CONSIDERED FOR AWARD.

The individual executing this Bid on behalf of the Company warrant to the City that the Company is authorized to do business in the State of Florida, is in good standing and that Company possesses all of the required licenses and certificates of competency required by the State of Florida and Broward County to provide the goods or perform the services herein described.



The signed bid shall be considered an offer on the part of the proposer or **Vendor**, which offer shall be deemed accepted upon approval by the City Commission of the City of Pembroke Pines and in case of default on the part of the proposer or **Vendor** after such acceptance, the City of Pembroke Pines may take such action as it deems appropriate including legal action for damages or specific performance.

9.23 MANUFACTURER'S CERTIFICATION

The City of Pembroke Pines reserves the right to request from proposer separate manufacturer certification of all statements made in the proposal.

9.24 MODIFICATION OR WITHDRAWAL OF PROPOSAL

The City recommends for proposers to submit their proposals as soon as they are ready to do so. Please allow ample time to submit your proposals on the OpenGov website. Proposals may be modified or withdrawn prior to the deadline for submitting Proposals.

9.25 PUBLIC BID; BID OPENING AND GENERAL EXEMPTIONS

All submittals received by the deadline will be recorded, and will subsequently be publicly opened on the same business day at 2:30 pm at the office of the City Clerk, 4th Floor, 601 City Center Way, Pembroke Pines, Florida, 33025.

All Proposals received from Proposers in response to the solicitation will become the property of CITY and will not be returned to the Proposers. In the event of Contract award, all documentation produced as part of the Contract shall become the exclusive property of CITY. Proposers are requested to identify specifically any information contained in their Proposals which they consider confidential and/or proprietary and which they believe to be exempt from disclosure, citing specifically the applicable exempting law.

Pursuant to Section 119.071 of the Florida Statutes, sealed bids, proposals, or replies received by a Florida public agency shall remain exempt from disclosure until an intended decision is announced or until 30 days from the opening, whichever is earlier.

Therefore, proposers will not be able to procure a copy of their competitor's bids until an intended decision is reached or 30 days has elapsed since the time of the bid opening.

However, pursuant to Section 255.0518 of the Florida Statutes, when opening sealed bids that are received pursuant to a competitive solicitation for **construction or repairs on a public building or public work**, the entity shall:

- A. Open the sealed bids at a public meeting.
- B. Announce at that meeting the name of each bidder and the price submitted in the bid.
- C. Make available upon request the name of each bidder and the price submitted in the bid.



For solicitations that are **not** for “**construction or repairs on a public building or public work**” the City shall not reveal the prices submitted in the bids until an intended decision is announced or until 30 days from the opening, whichever is earlier.

9.26 RESERVATIONS FOR REJECTION AND AWARD

The City of Pembroke Pines reserves the right to accept or reject any and all bids or parts of bids, to waive irregularities and technicalities, and to request rebids. The City also reserves the right to award a contract on such items(s) or service(s) the City deems will best serve its interests. All bids shall be awarded to the most responsive/responsible proposer, provided the (City) may for good cause reject any bid or part thereof. It further reserves the right to award a contract on a split order basis, or such combinations as shall best serve the interests of the City unless otherwise specified. No premiums, rebates or gratuities permitted, either with, prior to, or after award. This practice shall result in the cancellation of said award and/or return of items (as applicable) and the recommended removal of proposer from bid list(s).

9.27 BID PROTEST

Any protests or challenges to this competitive procurement shall be governed by Section 35.38 of the City’s Code of Ordinances.

9.28 INDEMNIFICATION

The Successful Proposer shall pay all claims, losses, liens, settlements or judgments of any nature whatsoever in connection with the subsequent indemnifications including, but not limited to, reasonable attorney's fees (including appellate attorney's fees) and costs.

CITY reserves the right to select its own legal counsel to conduct any defense in any such proceeding and all costs and fees associated therewith shall be the responsibility of Successful Proposer under the indemnification agreement. Nothing contained herein is intended nor shall it be construed to waive City’s rights and immunities under the common law or Florida Statute 768.28 as amended from time to time.

Additional indemnification requirements may be included under Special Terms and Conditions and/or as part of a specimen contract included in the solicitation package.

General Indemnification: To the fullest extent permitted by laws and regulations, Successful Proposer shall indemnify, defend, save and hold harmless the CITY, its officers, agents and employees, harmless from any and all claims, damages, losses, liabilities and expenses, direct, indirect or consequential arising out of or in consequential arising out of or alleged to have arisen out of or in consequence of the products, goods or services furnished by or operations of the Successful Proposer or his subcontractors, agents, officers, employees or independent contractors pursuant to or in the performance of the Contract.

Indemnification for Design Professionals and Construction Contracts: The Successful Proposer shall indemnify and hold harmless the CITY, its officers and employees, from any and all liability, losses or damages, including reasonable attorneys' fees and costs of defense, which the CITY, its

officers and employees, may incur as a result of claims, demands, suits, causes of actions or proceedings of any kind or nature to the extent such claims are caused by the negligence, recklessness, or intentional wrongful conduct of the Successful Proposer and other persons employed or utilized by the Successful Proposer during performance of the resulting Agreement.

Patent and Copyright Indemnification: Successful Proposer agrees to indemnify, defend, save and hold harmless the CITY, its officers, agents and employees, from all claims, damages, losses, liabilities and expenses arising out of any alleged infringement of copyrights, patent rights and/or the unauthorized or unlicensed use of any invention, process, material, property or other work manufactured or used in connection with the performance of the Contract, including its use by CITY.

9.29 DEFAULT PROVISION

In the case of default by the proposer or **Vendor**, the City of Pembroke Pines may procure the articles or services from any other sources and hold the proposer or **Vendor** responsible for any excess costs occasioned or incurred thereby.

The City shall be the sole judge of nonperformance, which shall include any failure on the part of the successful Proposer to accept the Award, to furnish required documents, and/or to fulfill any portion of the contract within the time stipulated. Upon default by the successful Proposer to meet any terms of this agreement, the City will notify the Proposer five (5) days (weekends and holidays excluded) to remedy the default. Failure on the **Vendor's** part to correct the default within the required five (5) days shall result in the contract being terminated and upon the City notifying in writing the Vendor of its intentions and the effective date of the termination. The following shall constitute default:

- A. Failure to perform the Work required under the contract and/or within the time required or failing to use the subcontractor, entities and personnel as identified and set forth, and to the degree specified in the contract.
- B. Failure to begin the Work under this Bid within the time specified.
- C. Failure to perform the Work with sufficient Workers and equipment or with sufficient materials to ensure timely completion.
- D. Neglecting or refusing to remove materials or perform new Work where prior Work has been rejected as non-conforming with the terms of the contract.
- E. Becoming insolvent, being declared bankrupt, or committing act of bankruptcy or insolvency, or making an assignment renders the successful Proposer incapable of performing the Work in accordance with and as required by the contract.
- F. Failure to comply with any of the terms of the contract in any material respect.

In the event of default of a contract, the successful Proposer shall pay all attorney's fees and court costs incurred in collecting any damages. The successful Proposer shall pay the City for any and all costs incurred in ensuing the completion of the project.



Additional provisions may be included in the specimen contract.

9.30 ACCEPTANCE OF MATERIAL

The material delivered under this proposal shall remain the property of the seller until a physical inspection and actual usage of this material and/or services is made and thereafter accepted to the satisfaction of the City and must comply with the terms herein, and be fully in accord with specifications and of the highest quality. In the event the material and/or services supplied to the City are found to be defective or do not conform to specifications, the City reserves the right to cancel the order upon written notice to the seller and return product to seller at the sellers expense.

9.31 LOCAL GOVERNMENT PROMPT PAYMENT ACT

The City complies with Florida Statute 218.70, Local Government Prompt Payment Act.

9.32 SCRUTINIZED COMPANIES LIST

In accordance with Section 287.135, Florida Statutes, as amended, a company is ineligible to, and may not, bid on, submit a proposal for, or enter into or renew a contract with an agency or local governmental entity for goods or services of:

- A. Any amount if, at the time of bidding on, submitting a proposal for, or entering into or renewing such contract, the company is on the Scrutinized Companies that Boycott Israel List, created pursuant to Section 215.4725, Florida Statutes, or is engaged in a boycott of Israel; or
- B. One million dollars or more if, at the time of bidding on, submitting a proposal for, or entering into or renewing such contract, the company:
 1. Is on the Scrutinized Companies with Activities in Sudan List or the Scrutinized Companies with Activities in the Iran Terrorism Sectors List, created pursuant to Section 215.473, Florida Statutes; or
 2. Is engaged in business operations in Syria.

By submitting a bid, proposal or response, the company, its principals or owners, certify that they are not listed on the Scrutinized Companies that Boycott Israel List, Scrutinized Companies with Activities in Sudan List, Scrutinized Companies with Activities in the Iran Terrorism Sectors List, or is engaged in business operations in Syria.

9.33 PUBLIC RECORDS; TRADE SECRET, PROPRIETARY AND CONFIDENTIAL SUBMITTALS

The Proposer's response to this solicitation is a public record pursuant to Florida law, which is subject to disclosure by the City under the State of Florida Public Records Law, Florida Statutes Chapter 119.07 ("Public Records Law"). The City shall permit public access to all documents, papers, letters or other material submitted in connection with this solicitation and the Contract to be executed for this solicitation, subject to the provisions of Chapter 119.07 of the Florida Statutes.



Any language contained in the Proposer’s response to the solicitation purporting to require confidentiality of any portion of the Proposer’s response to the solicitation, except to the extent that certain information is in the City’s opinion a Trade Secret pursuant to Florida law, shall be void. If a Proposer submits any documents or other information to the City which the Proposer claims is Trade Secret information and exempt from Florida Statutes Chapter 119.07 (“Public Records Laws”), the Proposer shall clearly designate that it is a Trade Secret and that it is asserting that the document or information is exempt. The Proposer must specifically identify the exemption being claimed under Florida Statutes 119.07. The City shall be the final arbiter of whether any information contained in the Proposer’s response to the solicitation constitutes a Trade Secret.

Any claim of confidentiality on financial statements must be asserted at the time of submittal. The firm must identify the specific statute that authorizes the exemption from the Public Records Law. Please note that the financial statement exemption provided for in Section 119.071(1)c, Florida Statutes only applies to submittals in response to a solicitation for a “public works” project.

EXCEPT FOR CLEARLY MARKED PORTIONS THAT ARE BONA FIDE TRADE SECRETS PURSUANT TO FLORIDA LAW, DO NOT MARK YOUR RESPONSE TO THE SOLICITATION AS PROPRIETARY OR CONFIDENTIAL. DO NOT MARK YOUR RESPONSE TO THE SOLICITATION OR ANY PART THEREOF AS COPYRIGHTED. ALL DOCUMENTS THAT THE FIRM PURPORTS TO BE CONFIDENTIAL, PROPRIETARY OR A TRADE SECRET SHALL BE UPLOADED TO THE OPENGOV WEBSITE AS A SEPARATE ATTACHMENT CLEARLY IDENTIFYING THE EXEMPTION BEING CLAIMED UNDER FLORIDA STATUTES 119.07.

The city’s determination of whether an exemption applies shall be final, and the proposer agrees to defend, indemnify, and hold harmless the city and the city’s officers, employees, and agent, against any loss or damages incurred by any person or entity as a result of the city’s treatment of records as public records.

9.34 PURCHASING AGREEMENTS WITH OTHER GOVERNMENT AGENCIES

It is hereby made part of this solicitation that the submission of any bid response to this advertised request constitutes a bid made under the same or similar terms and conditions, for the same price, or better price, to other government agencies if agreeable by the proposer and the government agency.

At the option of the **Vendor**, the use of the contract resulting from this solicitation may be extended to other governmental agencies, including the State of Florida, its agencies, political subdivisions, counties, and cities.

Each governmental agency allowed by the **Vendor** to use this contract shall do so independently of any other governmental entity. Each agency shall be responsible for its own purchases and shall be liable only for goods or services ordered, received, and accepted. No agency receives any liability by virtue of this bid and subsequent contract award.

9.35 CONE OF SILENCE



Prohibited Communication: In accordance with the Cone of Silence Ordinance, Section 35.40 of the City’s Code of Ordinances, during the course of a sealed competitive solicitation, a cone of silence shall be in effect between:

- A. Any person or entity that seeks a contract, contract amendment, award, recommendation, or approval related to a sealed competitive solicitation or that is subject to being evaluated or having its response evaluated in connection with a sealed competitive solicitation, including a person or entity's representative; and
- B. The City Manager or any person or group of persons appointed or designated by the City Commission or the City Manager to evaluate, select, or make a recommendation to the City Commission or the City Manager regarding a sealed competitive solicitation, including any member of the selection/evaluation committee.

Effective Dates: A cone of silence shall be in effect during a sealed competitive solicitation process beginning upon the advertisement for the sealed competitive solicitation or during such other procurement activities as declared by the City Commission, and shall terminate at the time the City Commission takes final action or gives final approval of a contract, rejects all bids or responses to the sealed competitive solicitation, or takes other action which ends the sealed competitive solicitation process.

Permitted Communication: The cone of silence shall not apply to:

- A. Written or oral communications with legal counsel for the city, the Procurement Department staff for the city, and the person or persons designated in the sealed competitive solicitation as the contact person for clarification or information related to the sealed competitive solicitation.
- B. Public presentations, asking questions, or providing feedback at pre-bid meetings, site visits or conferences or at a selection, evaluation or negotiation meeting related to the sealed competitive solicitation.
- C. Contract negotiations with the selected entity.

Violations: Any action in violation of this section shall be cause for disqualification of the bid or the proposal.

9.36 E-VERIFY

Contractor certifies that it is aware of and complies with the requirements of Section 448.095, Florida Statutes, as may be amended from time to time and briefly described herein below.

A. Definitions for this Section:

1. “Contractor” means a person or entity that has entered or is attempting to enter into a contract with a public employer to provide labor, supplies, or services to such employer in exchange for salary, wages, or other remuneration. “Contractor” includes, but is not limited to, a vendor or consultant.

2. “Subcontractor” means a person or entity that provides labor, supplies, or services to or for a contractor or another subcontractor in exchange for salary, wages, or other remuneration.
3. “E-Verify system” means an Internet-based system operated by the United States Department of Homeland Security that allows participating employers to electronically verify the employment eligibility of newly hired employees.

B. Registration Requirement; Termination:

Pursuant to Section 448.095, Florida Statutes, effective January 1, 2021, Contractors, shall register with and use the E-verify system in order to verify the work authorization status of all newly hired employees. Contractor shall register for and utilize the U.S. Department of Homeland Security’s E-Verify System to verify the employment eligibility of:

1. All persons employed by a Contractor to perform employment duties within Florida during the term of the contract; and
2. All persons (including subvendors / subconsultants / subcontractors) assigned by Contractor to perform work pursuant to the contract with the City of Pembroke Pines. The Contractor acknowledges and agrees that registration and use of the U.S. Department of Homeland Security’s E-Verify System during the term of the contract is a condition of the contract with the City of Pembroke Pines; and
3. The Contractor shall comply with the provisions of Section 448.095, Fla. Stat., "Employment Eligibility," as amended from time to time. This includes, but is not limited to registration and utilization of the E-Verify System to verify the work authorization status of all newly hired employees. Contractor shall also require all subcontractors to provide an affidavit attesting that the subcontractor does not employ, contract with, or subcontract with, an unauthorized alien. The Contractor shall maintain a copy of such affidavit for the duration of the contract. Failure to comply will lead to termination of this Contract, or if a subcontractor knowingly violates the statute, the subcontract must be terminated immediately. Any challenge to termination under this provision must be filed in the Circuit Court no later than twenty (20) calendar days after the date of termination. Termination of this Contract under this Section is not a breach of contract and may not be considered as such. If this contract is terminated for a violation of the statute by the Contractor, the Contractor may not be awarded a public contract for a period of one (1) year after the date of termination.

9.37 JESSICA LUNSFORD ACT

Background screening requirements for **Vendor**’s performing services for or at City’s Charter Schools.

- A. Except as provided in §§1012.467 or 1012.468, Florida Statutes, non-instructional school employees or contractual personnel who:
1. are permitted access on school grounds when students are present,
 2. have direct contact with students or,
 3. have access to or control of school funds must meet level 2 screening requirements as described in §1012.32, Florida Statutes. Contractual personnel shall include any **Vendor**, individual, or entity under contract with the City engaged to perform services for or at City's Charter Schools.
- B. Every 5 years following employment or entry into a resulting contract in a capacity described in subsection (A), each person who is so employed or under contract with the City must meet level 2 screening requirements as described in §1012.32, Florida Statutes, at which time the City shall request the Department of Law Enforcement to forward the fingerprints to the Federal Bureau of Investigation for the level 2 screening. If, for any reason following employment or entry into a resulting contract in a capacity described in subsection (A), the fingerprints of a person who is so employed or under contract with the City are not retained by the Department of Law Enforcement under §1012.32(3)(a) and (b), Florida Statutes, the person must file a complete set of fingerprints with the City. Upon submission of fingerprints for this purpose, the City shall request the Department of Law Enforcement to forward the fingerprints to the Federal Bureau of Investigation for the level 2 screening, and the fingerprints shall be retained by the Department of Law Enforcement under §1012.32(3)(a) and (b), Florida Statutes. The cost of the state and federal criminal history check required by level 2 screening shall be borne by the **Vendor**, or the person fingerprinted. Under penalty of perjury, each person who is employed or engaged to perform a resulting contract in a capacity described in subsection (A) must agree to inform his or her employer or the party with whom he or she is under contract within 48 hours if convicted of any disqualifying offense while he or she is employed or under a resulting contract in that capacity.
- C. If it is found that a person who is employed or under contract in a capacity described in subsection (A) does not meet the level 2 requirements, the person shall be immediately suspended from working in that capacity and shall remain suspended until final resolution of any appeals.

9.38 PROHIBITION AGAINST CONSIDERING SOCIAL, POLITICAL OR IDEOLOGICAL INTERESTS IN GOVERNMENT CONTRACTING

Bidders are hereby notified of the provisions of Section 287.05701, Florida Statutes, as amended, that the City will not request documentation of or consider a Bidder's social, political, or ideological interests when determining if the Bidder is a responsible Bidder. Bidders are further notified that the



City's governing body may not give preference to a Bidder based on the Bidder's social, political, or ideological interests.



SECTION 10 - SPECIAL TERMS & CONDITIONS

10.1 PROPOSAL SECURITY APPLICABILITY AND AMOUNT

A Proposal Security shall be required, only for bidders that have a total cumulative base proposal amount that exceeds \$200,000. Proposal Security shall be in the amount of 5% of the total cumulative base amount proposed.

Note - Contingency is not to be counted in the total amount that the proposal security is based on.

10.2 PROPOSAL SECURITY REQUIREMENTS

For projects in which Proposal Securities are required, each Proposal must be accompanied by a certified or cashier's check or by a Bid Bond made payable to the City of Pembroke Pines on an approved form, duly executed by the Proposer as principal and having as surety thereon a surety company acceptable to CITY and authorized to write such Bond under the laws of the State of Florida. The agent or attorney in fact or other officer who signs a Bid Bond for a surety company must file with such bond a certified copy of their power of attorney authorizing them to do so.

Scanned Proposal Security: For projects in which Proposal Securities are required, Proposers must submit a scanned copy of their Proposal Security (certified check, cashier's check or a Bid Bond) with their bid submittal through OpenGov.

Physical Proposal Security: For projects in which Proposal Securities are required, Proposers should also submit their original Proposal Security (certified check, cashier's check or a Bid Bond) at time of the bid due date, or they may be deemed as non-responsive. The original Proposal Security should be in a sealed envelope, plainly marked "**BID SECURITY - IFB # RE-25-07 New Chiller for Studio 18**" and sent to the:

City of Pembroke Pines,
City Clerk's Office, 4th Floor,
601 City Center Way,
Pembroke Pines, Florida, 33025.

Opportunity to Cure: In the event that the proposer fails to submit the scanned and/or the physical proposal security, in the City's sole discretion, the City may allow the proposer to furnish the proposal security within 3 days of written notice of deficiency.

Successful Proposer: The Proposal Security of the Successful Proposer will be retained until such Proposer has executed the Contract and furnished the required insurance, payment and performance bonds, whereupon the Proposal Security will be returned. If the Successful Proposer fails to execute and deliver the Contract and furnish the required insurance and bonds within fifteen (15) calendar days of the Notice of Award, CITY may annul the Notice of Award and the entire sum of the Proposal Security shall be forfeited.

Three Lowest Proposers: The Proposal Security of the three (3) lowest Proposers will be returned within seven (7) calendar days after CITY and the Successful Proposer have executed the written



Contract or if no such written Contract is executed within ninety (90) calendar days after the date of the Proposal opening, upon the demand of any Proposer at any time thereafter, provided that the Proposer has not been notified of the acceptance of their Proposal.

All Other Proposers: Proposal Security of all other Proposer will be returned within seven (7) calendar days after the proposal opening.

10.3 PAYMENT AND PERFORMANCE BONDS

Regardless of the awarded contract amount, two (2) separate bonds (Payment and Performance Bonds) are required, and both must be approved by the City. The penal sum stated in each bond shall be 100% of the contract price.

Note - Contingency is not to be counted in the total amount that the payment and performance bonds are based on.

Coverage Period: The surety company shall only cover the period of performance / construction and not the labor warranty nor the manufacturer's warranty periods.

Successful Proposer: Within fifteen (15) calendar days after Notice of Award and in any event prior to commencing work, the **Vendor** shall execute and furnish to City a performance bond and a payment bond.

Minimum Requirements of Surety: Each bond shall be written by a corporate surety, having a resident agent in the State of Florida and having been in business with a record of successful continuous operation for at least five (5) years. The surety shall hold a current certificate of authority from the Secretary of Treasury of the United States as an acceptable surety on federal bonds in accordance with United States Department of Treasury Circular No. 570. If the amount of the Bond exceeds the underwriting limitation set forth in the circular, in order to qualify, the net retention of the surety company shall not exceed the underwriting limitation in the circular and the excess risks must be protected by coinsurance, reinsurance, or other methods, in accordance with Treasury Circular 297, revised September 1, 1978 (31DFR, Section 223.10, Section 223.11). Further, the surety company shall provide City with evidence satisfactory to City, that such excess risk has been protected in an acceptable manner. The surety company shall have at least the following minimum qualification in accordance with the latest edition of A.M. Best's Insurance Guide, published by Alfred M. Best Company, Inc., Ambest Road, Oldwick, New Jersey 08858:

B+ to A+

Performance Bond: The performance bond shall be conditioned that the **Vendor** performs the contract in the time and manner prescribed in the contract.

Payment Bond: The payment bond shall be conditioned that the **Vendor** promptly make payments to all persons who supply the **Vendor** with labor, materials and supplies used directly or indirectly by the **Vendor** in the prosecution of the work provided for in the Contract and shall provide that the surety shall pay the same in the amount not exceeding the sum provided in such bonds, together with interest at the maximum rate allowed by law; and that they shall indemnify and save harmless the



City to the extent of any and all payments in connection with the carrying out of said Contract which the City may be required to make under the law.

Recordation of Bonds with the County: Pursuant to the requirements of Section 255.05(1)(a), Florida Statutes, it shall be the duty of the **Vendor** to record the aforesaid payment and performance bonds in the public records of Broward County, with the **Vendor** to pay all recording costs.

10.4 OWNER'S CONTINGENCY

While the specifications contained in this solicitation and any ensuing Purchase Orders or contracts have incorporated all anticipated work to be accomplished, there may be unanticipated work required of the **Vendor** in conjunction with a specific project. For this reason, the City Commission may award a project with an "Owner's Contingency". This contingency or allowance authorizes the City execute change orders up to the amount of the contingency without the need to obtain additional Commission approval. The Owner's Contingency is usually based on a specified percent of the proposed project amount and is established for the specific project being performed under the contract. This dollar amount shall be shown on the specific project purchase order as a distinct item from the **Vendor's** overall offer to determine the total potential dollar value of the contract. It is hereby understood and agreed that the **Vendor** shall not expend any dollars in connection with the Owner's Contingency without the expressed prior approval of the City's authorized representative. Any Owner's Contingency funds that have not been utilized at the end of the project will remain with the Owner, the **Vendor** shall only be paid for the proposed project cost as approved by the City Commission along with any Owner Contingency expenses that were approved by the City's authorized representative.

10.5 TAX SAVER PROGRAM

The **Vendor** shall cooperate on certain projects to allow the City to avail itself of a sales tax savings program.

10.6 RELEASE OF LIEN

Vendor must provide an executed Partial/Final Release of Lien utilizing the City's standard Release of Lien Form in order for the City to release any payments to the Vendor.

10.7 SOLID WASTE CONSTRUCTION AND DEMOLITION DEBRIS COLLECTION AND DISPOSAL REQUIREMENTS

The City of Pembroke Pines has an exclusive solid waste franchise agreement with Waste Pro of Florida, Inc. for the collection and disposal of all solid waste including construction and demolition (C & D) debris. All applicants for bids to perform construction work for the City of Pembroke Pines shall be subject to the requirements found in the City's exclusive solid waste franchise agreement and must contract Waste Pro of Florida, Inc. for the collection and disposal of all construction and demolition debris generated at such construction job sites.

For the current applicable rates and fees for Waste Pro of Florida, Inc. dumpsters, roll-off containers, and other related solid waste service equipment needs, please contact David Perez, Waste Pro's Pembroke Pines Sales Representative at (954) 967-4200 or dperez@wasteprousa.com.



For further information related to the solid waste franchise requirements, please contact Rose Colombo, Solid Waste Franchise Agreement Contract Manager, at (954) 518-9011 or rcolombo@ppines.com.

For solid waste franchise enforcement questions, please contact the City of Pembroke Pines Code Compliance Unit at (954) 431-4466.

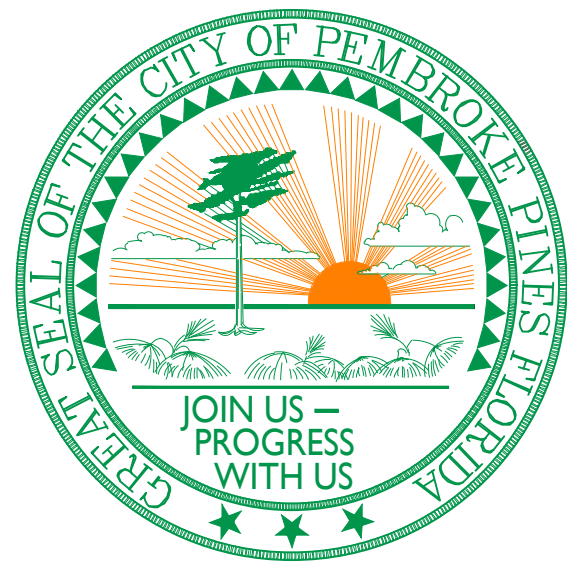

CITY OF PEMBROKE PINES

STUDIO 18

1101 POINCIANA DR

PEMBROKE PINES, FLORIDA 33025

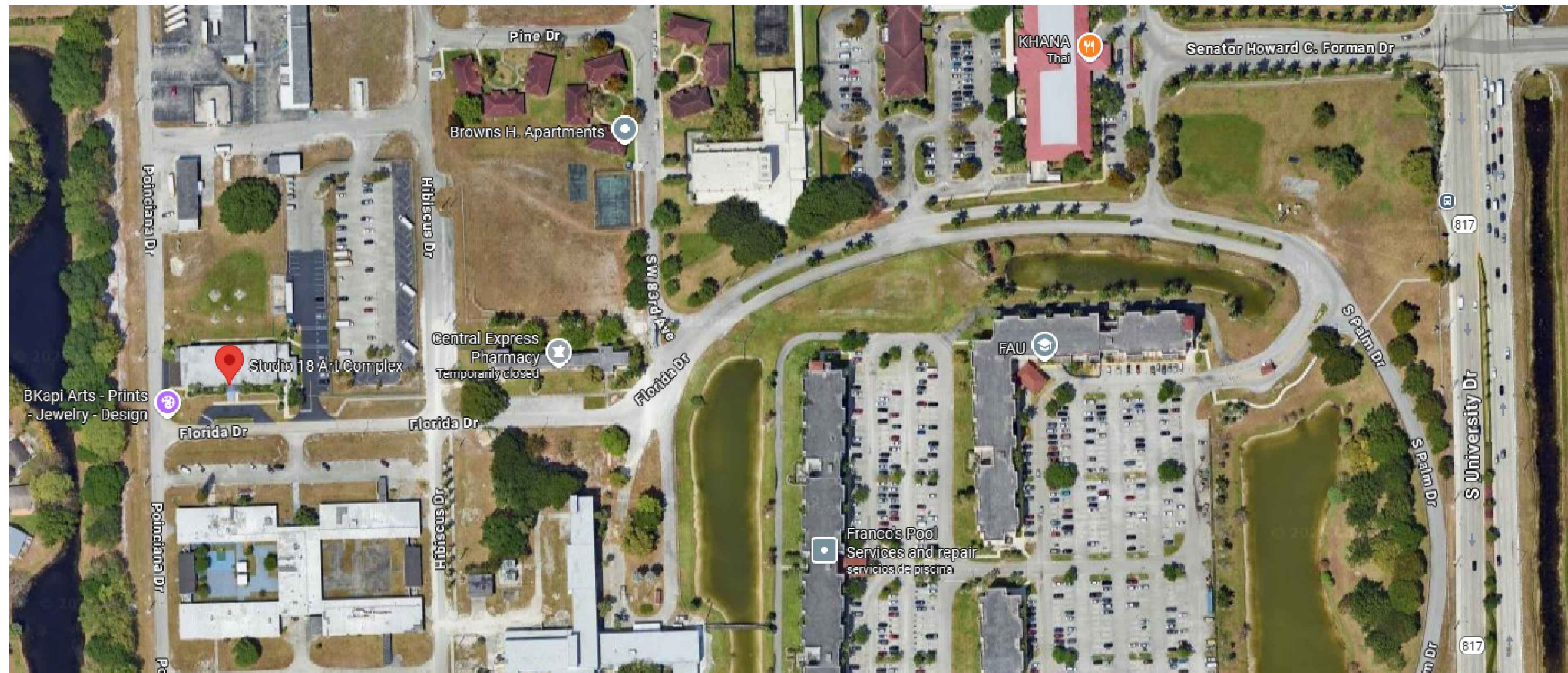

LOCATION MAP

(N.T.S.)

ELECTRICAL SCOPE OF WORK SUMMARY

1. INSTALL NEW UNDERGROUND CONDUIT TO FPL TRANSFORMER AS SPECIFIED. COORDINATE NECESSARY CONNECTION WITH FPL.
2. INSTALL NEW ELECTRIC METER AND WIRE GUTTER AS SPECIFIED.
3. INSTALL NEW SERVICE MAIN #2 OF 2 AND WIRING AS SPECIFIED.
4. INSTALL NEW GROUNDING BAR AND WIRING AS SPECIFIED.
5. INSTALL NEW UNDERGROUND CONDUIT AND WIRING TO CHILLER PAD LOCATION AS SPECIFIED.
6. INSTALL NEW DISCONNECT SWITCH AT CHILLER PAD AND MAKE ALL FINAL CONNECTIONS TO CHILLER AS SPECIFIED.

MECHANICAL SCOPE OF WORK SUMMARY

1. POUR NEW CONCRETE PAD TO SUPPORT NEW CHILLER AND WHERE SHOWN IN THE DRAWINGS.
2. INSTALL NEW CHILLER/PUMP PACKAGE AS SPECIFIED ON CONCRETE PAD.
3. INSTALL NEW UNDERGROUND AND ABOVE GROUND PIPING, INSULATION, AND ACCESSORIES AS SHOWN ON PLANS.
4. ISOLATE CHILLED WATER SERVICE TO BUILDING USING EXISTING VALVES OR FREEZE EXISTING PIPING TO MAKE CONNECTIONS OF NEW PIPING.
5. INSTALL NEW DOMESTIC WATER MAKE UP PIPING AND ACCESSORIES AS SHOWN.
6. SHUT DOWN OF CHILLED WATER SERVICE TO BUILDING MUST BE COORDINATED WITH FACILITY MANAGER.
7. START UP NEW CHILLER AND COMMISSION THE NEW SYSTEM.

GENERAL NOTES:

1. -----

DRAWING INDEX

-----	COVER SHEET
M-1	PARTIAL SITE / HVAC PLAN, EQUIPMENT SCHEDULE
M-2	CONTROLS, GENERAL NOTES, DETAILS
E-1	ELECTRICAL FLOOR/SITE PLAN
E-2	ELECTRICAL RISER DIAGRAM, PANEL SCHEDULE, NOTES

REVISIONS

NO.	DATE	BY	DESCRIPTION

PEMBROKE PINES COMMISSION

ANGELO CASTILLO	MAYOR
MICHAEL A. HERNANDEZ	VICE MAYOR - DISTRICT 4
THOMAS GOOD JR.	DISTRICT 1
JAY D. SCHWARTZ	DISTRICT 2
MARIA RODRIGUEZ	DISTRICT 3
CHARLES F. DODGE	CITY MANAGER

PROJECT MANAGER:

DATE: 09-09-2025

SHEET NAME: ----

PROJECT TITLE: STUDIO 18



revisions:

AIR COOLED CHILLER SCHEDULE

UNIT NUMBER	MODEL NUMBER	NOMINAL TONS	OPERATING WEIGHT (lbs)	EVAPORATOR DATA						CONDENSER DATA		COMPRESSOR DATA			EER / IPLV	ELECTRICAL DATA				PUMP DATA				
				EWT (°F)	LWT (°F)	FLOW (gpm)	#PASS	PD (ft)	FOULING FACTOR	AMBIENT (°F)	#FANS / F.L.A.	COMPRESSOR TYPE	# OF COMPRESSORS	RLA CURRENT (A)		STARTER TYPE	VOLTAGE	MCA	MCOP	INPUT POWER (KW)	PUMP TYPE	AVAIL HEAD @CONN.	RLA CURRENT (A)	PUMP FLOW
CH-1	CGAM040A2	40	4431	57	45	81.7	1	11.9	0.0001	95	4/6.7	SINGLE POINT	4	39.1/EA	11.7/16.6	ATL	208	212	300	41.8	DUAL HIGH HEAD	70.7	13.6	VAR SPEED DRIVE

1. BASIS OF DESIGN IS TRANE, CARRIER, YORK, DAIKIN ARE ACCEPTABLE ALTERNATES PROVIDED THEY DEMONSTRATE SUFFICIENT EQUALITY TO THE PRODUCT SPECIFIED AND COMPLIANCE WITH THE REST OF THE SPECIFICATIONS.
 2. CONSTRUCT CHILLER USING FULLY HERMETIC SCROLL TYPE COMPRESSORS WITH R454B OPTIMIZED AND DEDICATED SCROLL PROFILE. REFRIGERANT SHALL HAVE A GWP OF LESS THAN 600.
 3. EACH COMPRESSOR SHALL HAVE OVERLOAD PROTECTION INTERNAL TO THE COMPRESSOR.
 4. THE EVAPORATOR SHALL BE A HIGH EFFICIENCY, BRAZED PLATE-TO-PLATE TYPE HEAT EXCHANGER CONSISTING OF PARALLEL PLATES. BRAZE PLATES SHALL BE STAINLESS STEEL WITH COPPER BRAZE MATERIAL.
 5. INSULATE THE EVAPORATOR WITH A MINIMUM OF 0.75 INCH (K=0.28) UV RATED INSULATION.
 6. FACTORY INSTALLED CLEANABLE STRAINER.
 7. ALL CHILLERS INSTALLED IN THE US ARE REQUIRED TO BY STARTED UP BY TRANE TO VALIDATE FACTORY WARRANTY.
 8. ALL CHILLERS INSTALLED IN THE US ARE REQUIRED TO BY STARTED UP BY TRANE TO VALIDATE FACTORY WARRANTY.
 9. LOW SOUND FANS SHALL BY DYNAMICALLY BALANCED AND DIRECT DRIVEN.
 10. ALL CONDENSER FAN TEAO MOTORS HAVE PERMANENTLY LUBRICATED BALL BEARINGS AND EXTERNAL OVERLOAD PROTECTION.
 11. FACTORY INSTALLED FREEZE PROTECTION.
 12. PUMP PACKAGE THAT INCLUDES TWO HIGH HEAD PUMPS, A SINGLE VFD, DRAINAGE VALVES, SHUT-OFF VALVES AT ENTERING AND LEAVING CONNECTIONS.
 13. ELASTOMERIC ISOLATORS AT PIPE CONNECTIONS TO EVAPORATOR.
 14. 5 YEAR COMPRESSOR PARTS ONLY WARRANTY.
 15. SELECTION AMBIENT TEMPERATURE = 95°F
 16. MINIMUM FLOW = 67.1 gpm
 17. FACTORY INSTALLED WATER STRAINER.
 18. DUAL, HIGH HEAD, SHP PUMP PACKAGE WITH SINGLE VFD.
 19. A WEIGHTED 100% SOUND POWER = 89 dba.
 20. MANUFACTURER PROVIDE THE NECESSARY WIND LOAD CALCULATIONS, ATTACHMENT DETAILS TO COMPLY WITH FBC 2023 - MECHANICAL AND BROWARD COUNTY ORDINANCES.

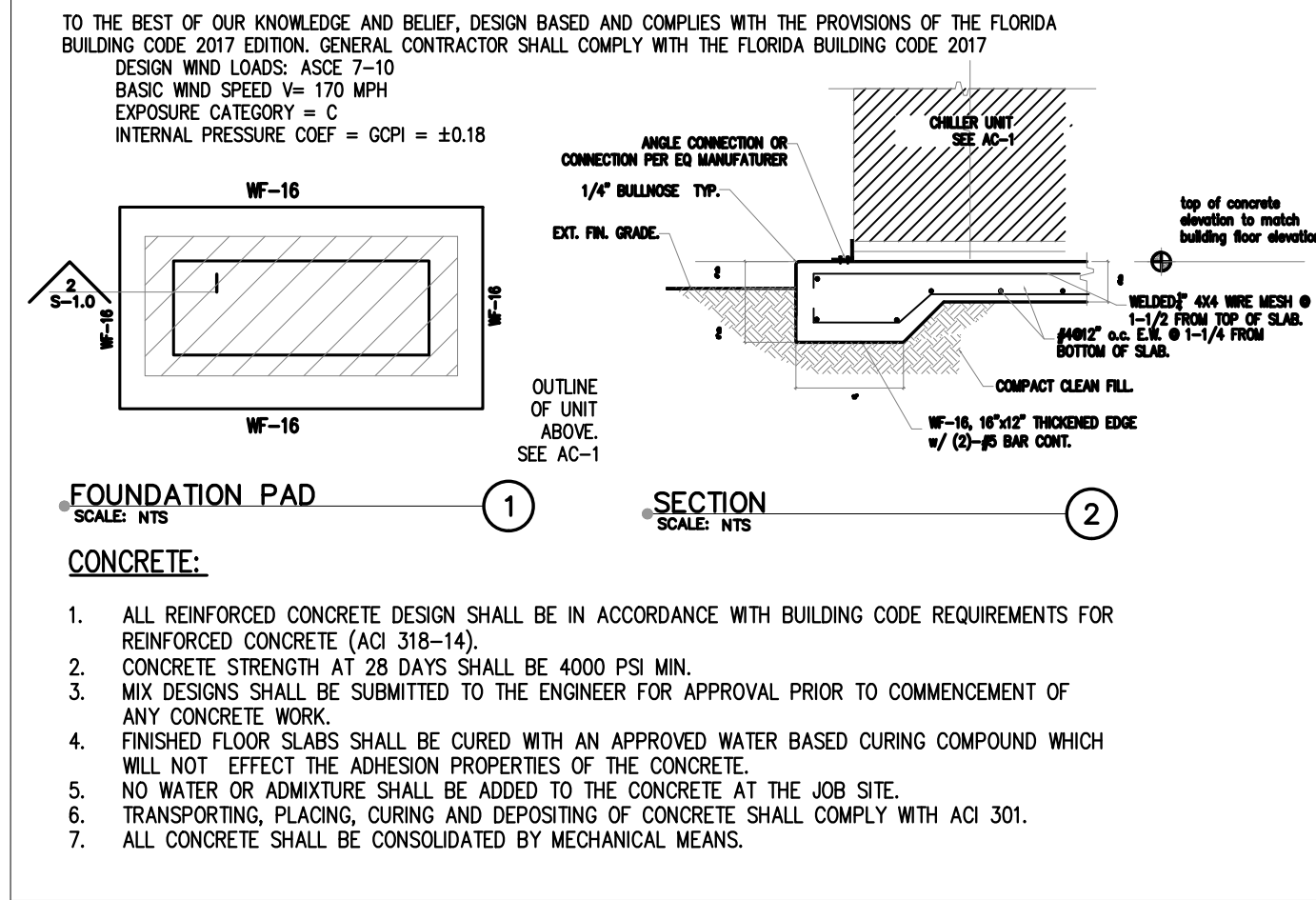
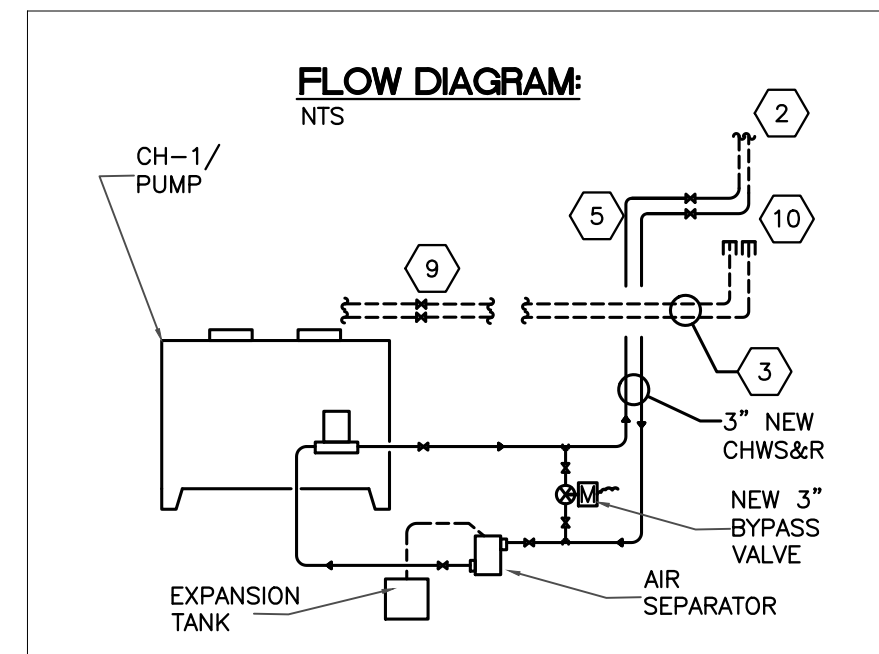

#	DRAWING NOTES
1	NEW PROPOSED 40-TON AIR COOLED CHILLER
2	EXISTING EXTERIOR CHILLED WATER RISER TO REMAIN.
3	EXISTING DISTRICT CHILLED WATER SUPPLY/RETURN UNDERGROUND PIPING TO BE ABANDONED IN PLACE.
4	NEW AIR COOLED CHILLER AND APPURTENANCES
5	NEW 3" CHWS&R UNDERGROUND INSULATED PIPING 12" DEEP TRENCH BELOW GRADE.
6	CONTRACTOR TO INSTALL NEW 15'-7" L x 8'-6" W x 6" H LEVEL FOUNDATION CONCRETE PAD WITH A 6" OFFSET FROM EQUIPMENT LINE. SEE DETAIL 1. TOP ELEVATION OF CONCRETE PAD TO BE EQUAL TO THE ELEVATION OF THE MAIN BUILDING FINISHED FLOOR.
7	30 GAL BLADER TANK TYP TACO CA90-150
8	AIR SEPARATOR W/STRAINER TYP TACO ACT03F-150
9	EXISTING CHWS&R SHUT OFF VALVES IN UNDERGROUND CONCRETE BOX LOCATED AT NE CORNER OF HIBISCUS AND FLORIDA DR.
10	CONTRACTOR TO CAP EXISTING CHWS&R AT 12" ABOVE GRADE AND CONNECT NEW CHWS&R 36" ABOVE GRADE TO EXISTING BUILDING PIPING.
11	EXISTING AHUS WITH 2-WAY CONTROL VALVES TO REMAIN

MECHANICAL SCOPE OF WORK SUMMARY

- POUR NEW CONCRETE PAD TO SUPPORT NEW CHILLER AND WHERE SHOWN IN THE DRAWINGS.
- INSTALL NEW CHILLER/PUMP PACKAGE AS SPECIFIED ON CONCRETE PAD.
- INSTALL NEW UNDERGROUND AND ABOVE GROUND PIPING, INSULATION, AND ACCESSORIES AS SHOWN ON PLANS.
- ISOLATE CHILLED WATER SERVICE TO BUILDING USING EXISTING VALVES OR FREEZE EXISTING PIPING TO MAKE CONNECTIONS OF NEW PIPING.
- INSTALL NEW DOMESTIC MAKE UP WATER PIPING AND ACCESSORIES AS SHOWN.
- SHUT DOWN OF CHILLED WATER SERVICE TO BUILDING MUST BE COORDINATED WITH FACILITY MANAGER.
- START UP NEW CHILLER AND COMMISSION THE NEW SYSTEM.

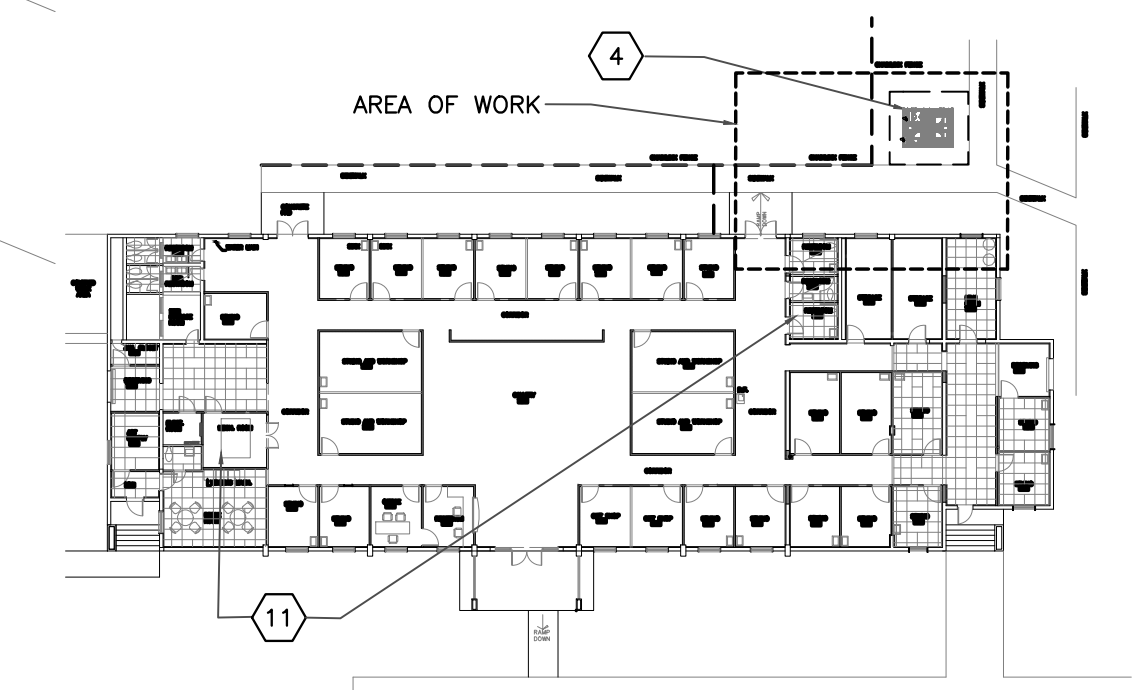
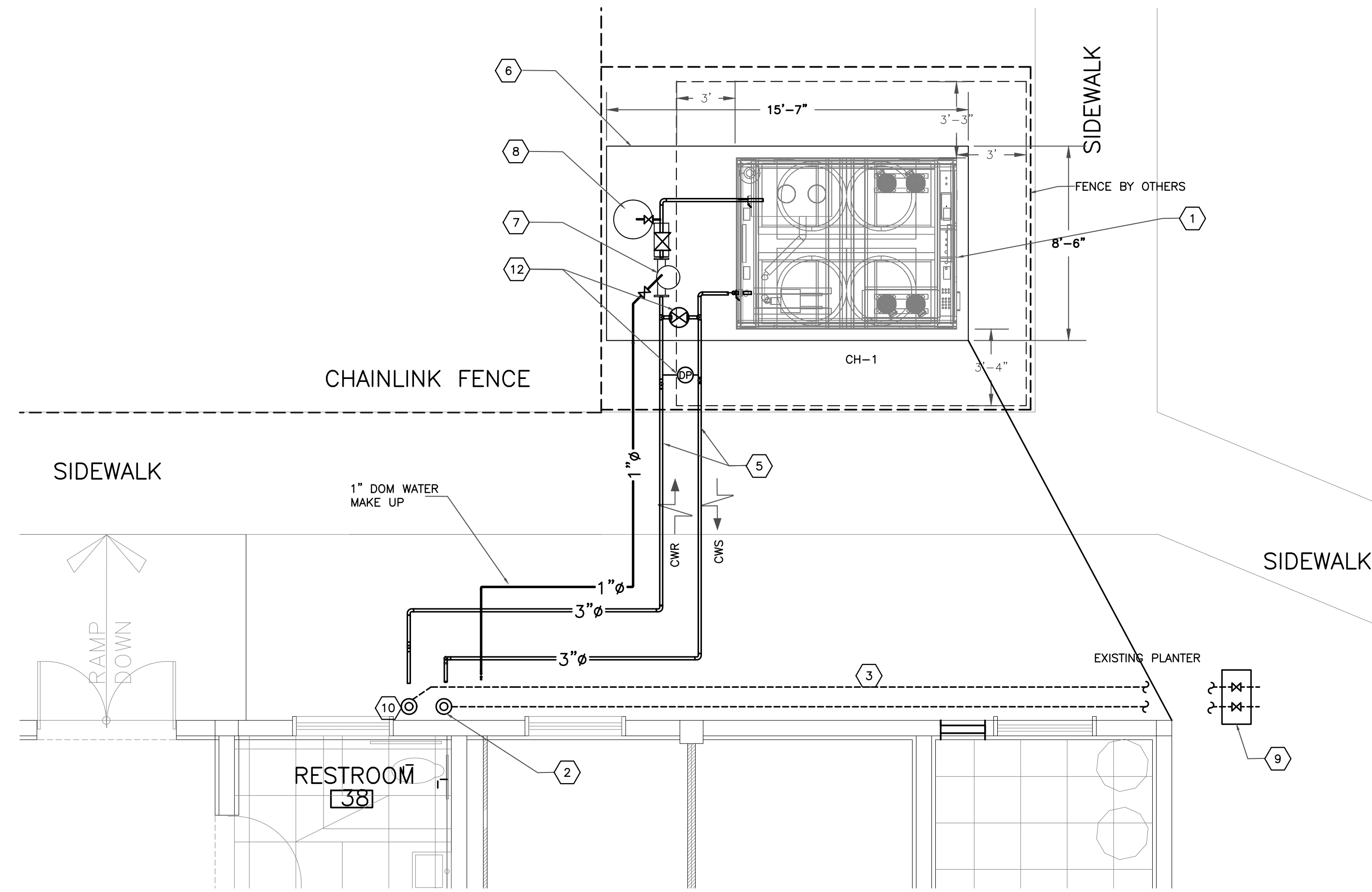

CITY OF PEMBROKE PINES - ART COLONY - STUDIO 18
UPGRADE HVAC SYSTEM
1101 POINCIANA DRIVE
PEMBROKE PINES, FL. 33026

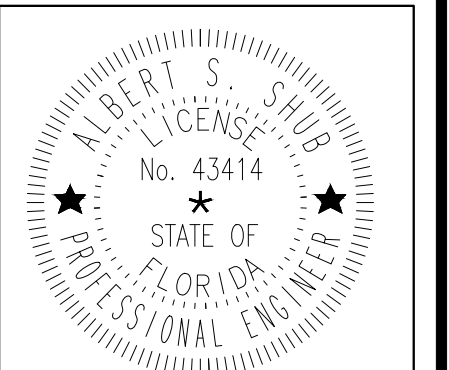

JOB NUMBER: 25025
 ALBERT S. HUB
 P.E. 0043414 M.E.
 EB0003862
 FLORIDA ENGINEERING SERVICES
 MECHANICAL AND ELECTRICAL ENGINEERS

FES

34 N.W. 168TH STREET
 NORTH MIAMI BEACH, FL 33169
 TELEPHONE: (305) 653-0212
 FAX: (305) 653-0232
 E-mail: AlbertS@esinc.biz

drawn by: AS
 date: 09-09-2025
 sheet no: M-1
 project:

revisions:

GENERAL AIR CONDITIONING NOTES:

- THESE DRAWINGS ARE RESULTING INSTALLATION ARE INTENDED TO COMPLY WITH: SEE ADDITIONAL COMPLIANCE NOTES.
- THE DRAWINGS ARE TO BE CONSIDERED DIAGRAMMATIC, NOT NECESSARILY SHOWING IN DETAIL OR TO SCALE ALL OF THE MINOR ITEMS. UNLESS SPECIFIC DIMENSIONS ARE SHOWN, THE STRUCTURAL, ARCHITECTURAL AND SITE CONDITIONS SHALL GOVERN THE EXACT LOCATIONS. CONTRACTOR SHALL FOLLOW DRAWINGS IN LAYING OUT WORK, CHECK DRAWINGS OF ALL TRADES TO VERIFY SPACES IN WHICH WORK WILL BE INSTALLED AND MAINTAIN MAXIMUM HEADROOM, AND SPACE CONDITIONS AT ALL POINTS. WHERE HEAD ROOM, OR SPACE CONDITIONS APPEAR INADEQUATE, ARCHITECT/ENGINEER SHALL BE NOTIFIED BEFORE PROCEEDING WITH INSTALLATION. THIS CONTRACTOR SHALL, WITHOUT EXTRA CHARGE, MAKE FIELD MODIFICATION IN LAYOUT AS NEEDED TO PREVENT CONFLICT WITH WORK OF VARIOUS TRADES OF FOR PROPER EXECUTION OF THE WORK.
- EXAMINE ALL DRAWINGS CAREFULLY PRIOR TO SUBMITTING A BID. CONTRACTOR WILL BE REQUIRED TO FURNISH, INSTALL AND/OR CONNECT WITH APPROPRIATE SERVICES ALL AIR CONDITIONING ITEMS SHOWN ON ANY OF THE ARCHITECTURAL, PLUMBING, ELECTRICAL AND SPRINKLER DRAWINGS WITHOUT ADDITIONAL EXPENSE TO THE OWNER. IF DISCREPANCIES, CONFLICTS, INTERFERENCES OR OMISSIONS OCCUR BETWEEN DRAWINGS, NOTIFY IN WRITING THE ARCHITECT/ENGINEER IN AMPLE TIME TO PERMIT REVISIONS BEFORE THE BIDS ARE SUBMITTED.
- INSTALL MATERIALS AND EQUIPMENT IN A NEAT AND FIRST CLASS WORKMANLIKE MANNER. THE OWNER RESERVES THE RIGHT TO DIRECT REMOVAL AND REPLACEMENT OF ITEMS, WHICH, IN HIS OPINION, DO NOT PRESENT A NEAT AND WORKMANLIKE APPEARANCE. REMOVAL AND REPLACEMENT IS TO BE DONE IMMEDIATELY WHEN DIRECTED BY THE OWNER IN WRITING, AT THE SOLE EXPENSE OF CONTRACTOR.
- START OF WORK BY CONTRACTOR SHALL BE CONSIDERED AS ACCEPTANCE BY HIM OF ALL CLAIMS OR QUESTIONS AS TO SUITABILITY OF THE WORK OF OTHER TRADES OR OTHER CONTRACTORS TO RECEIVE HIS WORK. THIS CONTRACTOR SHALL REMOVE AND REPLACE, AT HIS EXPENSE, ALL AIR CONDITIONING WORK WHICH MAY HAVE TO BE REMOVED BECAUSE OF INTERFERENCE WITH OTHER TRADES.
- THE CONTRACTOR SHALL OBTAIN AND PAY ALL INSURANCE, FEES, PERMITS ASSOCIATION DUES, ROYALTIES AND TAXES OF WHATEVER NATURE SHALL APPLY TO THIS WORK. HE SHALL ALSO PAY ALL INSPECTION FEES AS MAY BE REQUIRED BY LAW OR ORDINANCE AND KEEP THE OWNER HARMLESS FROM ANY DAMAGE AND EXPENSE ARISING FROM ANY VIOLATION OF THE LAWS, RULES OR ORDINANCES.
- THE WORD "AIR CONDITIONING" MEANS HEATING, VENTILATION, AIR CONDITIONING, DUCTWORK, PIPING, REFRIGERANT LINES, CONTROLS, SMOKE AND FIRE DAMPERS ETC.
- PROVIDE MEANS "FURNISH AND INSTALL".
- DO A COMPLETE JOB, EVERYTHING CONNECTED, READY FOR USE.
- SHOP DRAWINGS: THE CONTRACTOR SHALL FURNISH THE ENGINEER WITH SHOP DRAWINGS OF EQUIPMENT PRIOR TO PURCHASE FOR APPROVAL.
- AT COMPLETION OF THE HVAC CONTRACTOR SHALL GIVE THE OWNER AN AS-BUILT SET OF REPRODUCIBLE DRAWINGS SHOWING THE EXACT AND COMPLETE INSTALLATION.
- ALL AIR AND WATER SYSTEMS SHALL BE TESTED AND BALANCED BY AN INDEPENDENT TEST AND BALANCE COMPANY. PROVIDE T & B REPORTS PROVIDE T & B REPORTS IN ACCORDANCE WITH AIR BALANCE COUNCIL STANDARDS SIGNED AND SEALED BY A FLORIDA REGISTERED ENGINEER. ALL AIR AND WATER SYSTEMS SHALL BE BALANCED TO WITHIN 10% OF THE QUANTITIES SHOWN ON THE PLANS. THE HVAC CONTRACTOR SHALL INCLUDE THE COST OF PULLEY AND BELT CHANGES, AND PROVIDE THE TEST AND BALANCE FIRM WITH SHOP DRAWINGS ON ALL EQUIPMENT, PIPING AND DUCTWORK. DURING CONSTRUCTION, THE HVAC CONTRACTOR, THE HVAC CONTRACTOR SHALL ENSURE AND CONFIRM ADEQUATE SERVICE AND ACCESS CLEARANCES FOR ALL DAMPERS, MOTORS, ETC. TEST AND BALANCE OF THE RESIDENTIAL SYSTEMS MAY BE DONE BY THE MECHANICAL CONTRACTOR AND SHALL INCLUDE COMFORT BALANCE VISITS TO THE RESIDENCES IF REQUIRED.
- THE HVAC CONTRACTOR SHALL WARRANT ALL WORKMANSHIP AND MATERIALS FOR ONE YEAR FROM THE DATE OF FINAL WORK ACCEPTANCE BY OWNER. ANY BREAKDOWN OCCURRING IN FIRST YEAR SHALL BE REPAIRED AT NO EXPENSE TO THE OWNER. THE COMPRESSOR (S) SHALL HAVE A FIVE YEAR WARRANTY.
- MOUNT ALL EQUIPMENT FOR WIND LOADS AND MOUNTING HEIGHTS AS REQUIRED BY LOCAL CODES.
- ALL LOUVERS, GRILLES, PIPING, ETC. SHALL BE PAINTED TO MATCH SURROUNDING COLOR AND TEXTURES AS REQUIRED BY ARCHITECT. VERIFY COLOR AND TEXTURE WITH ARCHITECT. PAINT ALL EXPOSED MECHANICAL EQUIPMENT WITH BENJAMIN MOORE EPOXY ENAMEL 1B2.
- ALL CUTTING, PATCHING, STRUCTURAL STEEL, WEATHER PROOFING, PAINTING, AND WALL OPENINGS SHALL BE BY THE GENERAL CONTRACTOR.
- ALL OPENINGS IN BUILDING STRUCTURE, FOR DUCTWORK, PIPING, ETC. TO BE 1/2" LARGER (ON ALL SIDES) THEN THE OUTSIDE DIMENSIONS. FILL VOIDS WITH FIRE RETARDANT SILICONE FOAM (I.E. CHASE-FOAM CTC PR-855 BY CHASE TECHNOLOGY CORP.).
- PROVIDE FLEXIBLE DUCT CONNECTORS, RATED AS REQUIRED, TO ALL MECHANICAL EQUIPMENT.
- CONTRACTOR TO PROVIDE A COMPLETE SET OF SHOP DRAWINGS FOR ALL DUCT LAYOUT INCLUDING APARTMENT. CONTRACTOR TO VERIFY FIELD CONDITIONS AND NOTE ANY CONFLICT ON THE SHOP DRAWING FOR ENGINEER TO COMMENT.
- CONTRACTOR IS TO PROVIDE SHOP DRAWINGS AND SUBMITTALS BASED ON THE APPROVED SET OF DRAWINGS. ANY DEVIATION FROM THE ORIGINAL DESIGN MUST BE BROUGHT UP TO THE ATTENTION OF THE ENGINEER OF RECORD FOR REVIEW AND COMMENTS.
- PROVIDE MAINTENANCE AND OPERATION MANUAL ON ALL MECHANICAL EQUIPMENT OR SYSTEMS. PROVIDE 5 SETS OF SUBMITTALS ON ALL HVAC EQUIPMENT. SUBMITTALS SHALL HAVE A SUMMARY SHEET SHOWING ALL SCHEDULED INFORMATION.
- CONTRACTORS AND EQUIPMENT VENDORS ARE TO PROVIDE SUFFICIENT TRAINING AND INSTRUCTION TO THE FACILITY OPERATOR ON THE PROPER USE, ADJUSTMENT, AND MAINTENANCE OF THE EQUIPMENT AND SYSTEMS INSTALLED

A/C LEGEND:

- ~ PIPE CONTINUATION
- ⊘ SHUT-OFF VALVE IN PIPE
- FLOW DIRECTION
- EXISTING CHILLED WATER PIPING. SEE FLOOR PLANS FOR SIZES.
- _____ NEW CHILLED WATER PIPING. SEE FLOOR PLANS FOR SIZES.

MATERIALS:

- CHILLED WATER PIPING SHALL BE SCHEDULE 40 BLACK STEEL PIPE (ASTM C552) AND FITTING ALL MADE IN THE U.S.A. SEE CHILLED WATER PIPING INSULATION SPECIFICATIONS BELOW.
- TWO-PIECE, PREFORMED CLOSED CELL FOAMGLASS PIPE INSULATION WITH 0.016 INCH ALUMINUM JACKET, FITTINGS FINISHED WITH MASTIC AND REINFORCED WITH GLASS FABRIC WITH FIRE RESISTANT JACKET.
 - 2" THICK FOR ALL PIPE SIZES.
 - EQUIVALENT TO PITTSBURGH CORNING FOAMGLASS.
 - VAPOR BARRIER JACKET: KRAFT REINFORCED FOL WITH SELF-SEALING ADHESIVE.
 - EXTERIOR ABOVE GRADE APPLICATION
 - PVC JACKET, ONE-PIECE, PREFORMED TYPE.
 - MAXIMUM WATER VAPOR TRANSMISSION RATING: 0.01 PERMS.
 - 'K' VALUE OF 0.33 AT 75 DEGREE F.

ADDITIONAL COMPLIANCE NOTES:

- THESE ENGINEERING DOCUMENTS AND THE RESULTING INSTALLATION OF THE DEPICTED HVAC SYSTEMS FOR THIS PROJECT ARE INTENDED TO CONFORM TO THE FOLLOWING CODES AND STANDARDS:
 - FLORIDA BUILDING CODE 8TH EDITION (2023)
 - FLORIDA BUILDING CODE EXISTING BUILDINGS 8TH EDITION (2023)
 - FLORIDA BUILDING CODE MECHANICAL 8TH EDITION (2023)
 - FLORIDA ENERGY CONSERVATION CODE 8TH EDITION (2023)
 - FLORIDA FIRE PREVENTION CODE 8TH EDITION (2023)
 - ASHRAE 2021 FUNDAMENTALS HANDBOOK
 - FLORIDA BUILDING CODE EXISTING BUILDING 8TH EDITION (2023)
 - NFPA 70
- IF WORK AS LAID OUT, INDICATED OR SPECIFIED IS CONTRARY TO OR CONFLICTS WITH THE LISTED CODES AND STANDARDS, THE CONTRACTOR SHALL REPORT IN WRITING TO THE ARCHITECT/ENGINEER BEFORE SUBMITTING A BID. THE ARCHITECT/ENGINEER WILL THEN ISSUE INSTRUCTIONS AS HOW TO PROCEED.
- ALL EQUIPMENT IS TO BE INSTALLED PER THE MANUFACTURER'S INSTRUCTIONS, SPECIFICATIONS, AND RECOMMENDATIONS FOR SAFE AND EFFICIENT OPERATIONS. ALL MANUFACTURER OPERATION AND MAINTENANCE GUIDES SHALL BE ISSUED TO THE BUILDING OPERATOR AFTER SUCCESSFUL COMPLETION OF MAINTENANCE AND/OR PREVENTATIVE MAINTENANCE PROCEDURES TRAINING OF THE BUILDING OPERATORS.
- DESIGN CRITERIA INCLUDES BUT NOT LIMITED TO:
 - DEFERRED SUBMITTALS - THE FOLLOWING ITEMS WILL BE ENGINEERED BY OTHERS. SIGNED AND SEALED DRAWINGS FOR THESE WILL BE SUBMITTED FOR SEPARATE PERMITS PRIOR TO INSTALLATION:
 - EXTERIOR EQUIPMENT SUPPORT DETAILS, ANCHORING METHODS, TIE-DOWN DETAILS, AND WINDLOAD CALCULATIONS.

SYSTEM COMMISSIONING REQUIREMENTS

UPON COMPLETION OF SUCCESSFUL INSTALLATION, THE MECHANICAL SYSTEMS LISTED HEREIN SHALL BE FULLY COMMISSIONED BY A CERTIFIED COMMISSIONING AUTHORITY. THE COMMISSIONING AUTHORITY, HIRED BY THE GENERAL CONTRACTOR OR DEVELOPER, SHALL PREPARE A COMPLETE WRITTEN COMMISSIONING PLAN BEFORE THE ONSET OF CONSTRUCTION IN ACCORDANCE WITH SECTION C408 OF THE FLORIDA ENERGY CONSERVATION CODE 8TH EDITION (2023)

THE SYSTEMS THAT WILL REQUIRE COMMISSIONING ARE THE FOLLOWING:

- NEW AIR COOLED CHILLER/PUMP PACKAGE

PRELIMINARY COMMISSIONING REPORT MUST SUBMITTED TO THE BUILDING DEVELOPER/OPERATOR WITHIN 90-DAYS OF THE DATE OF RECEIPT OF CERTIFICATE OF OCCUPANCY.

CHILLER COMMISSIONING MUST INCLUDE WITNESSING START/STOP OF THE CHILLER PER SCHEDULE, COMPRESSOR STAGING BASED ON CHILLED WATER SUPPLY TEMPERATURE, AND CONDENSER FAN CONTROL PER MANUFACTURER'S SEQUENCE OF OPERATIONS. ALL COMMISSIONING SHALL BE DONE IN ACCORDANCE WITH ASHRAE GUIDELINE 0 AND GUIDELINE 1.1.

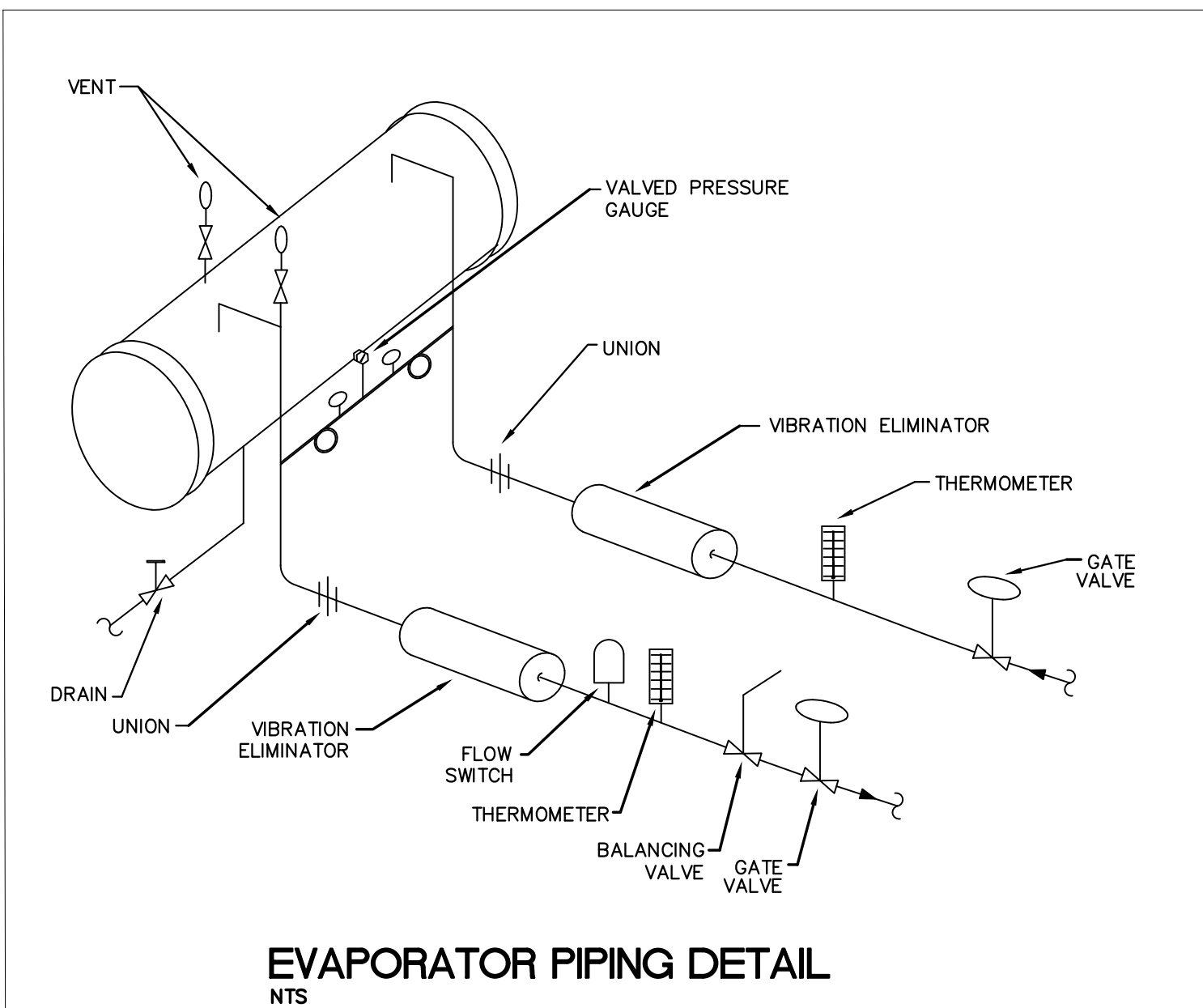

EVAPORATOR PIPING DETAIL
NTS

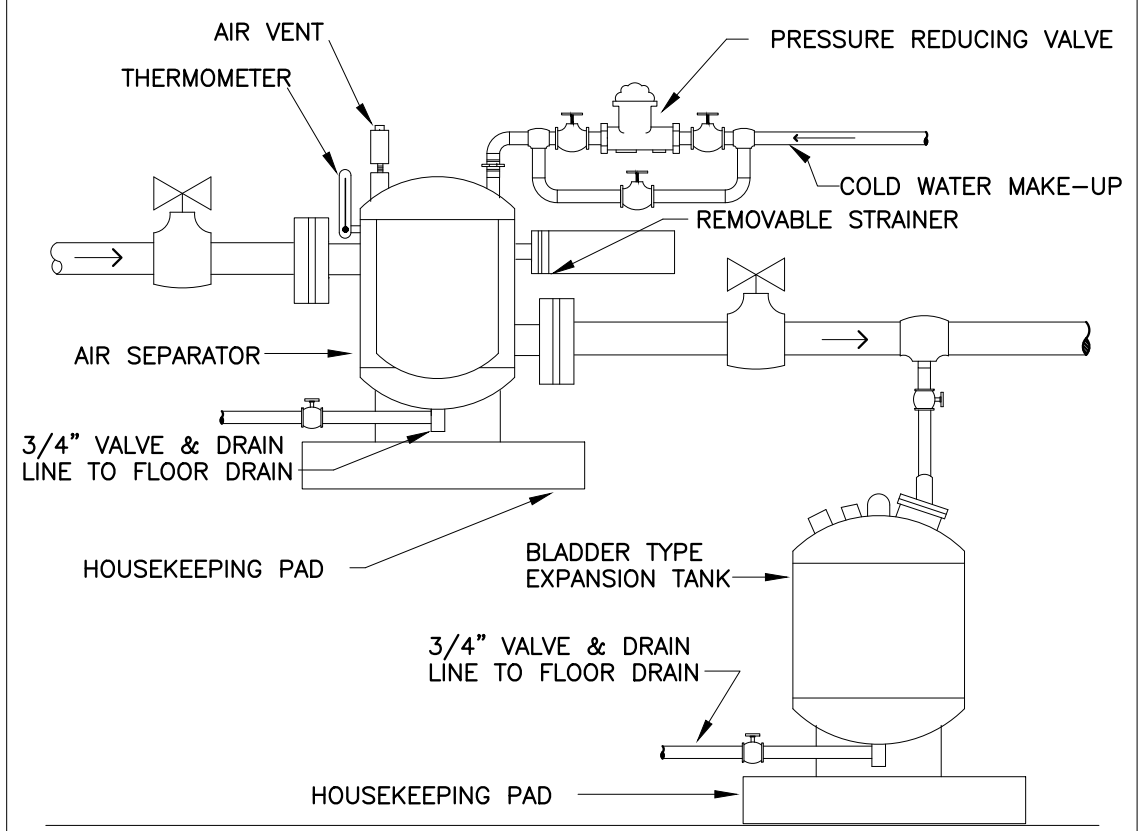

AIR SEPARATOR AND EXPANSION TANK DETAIL
NTS

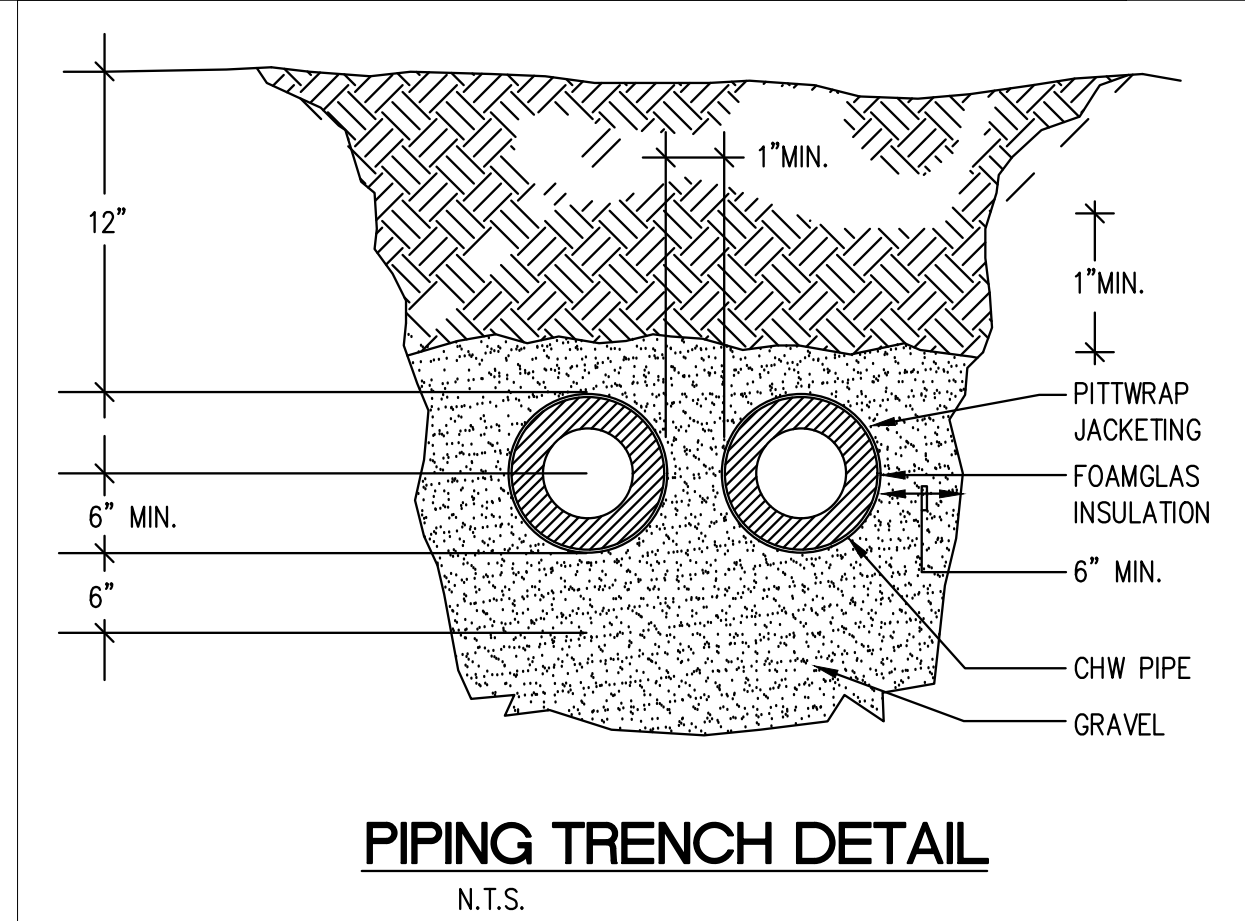

PIPING TRENCH DETAIL
NTS

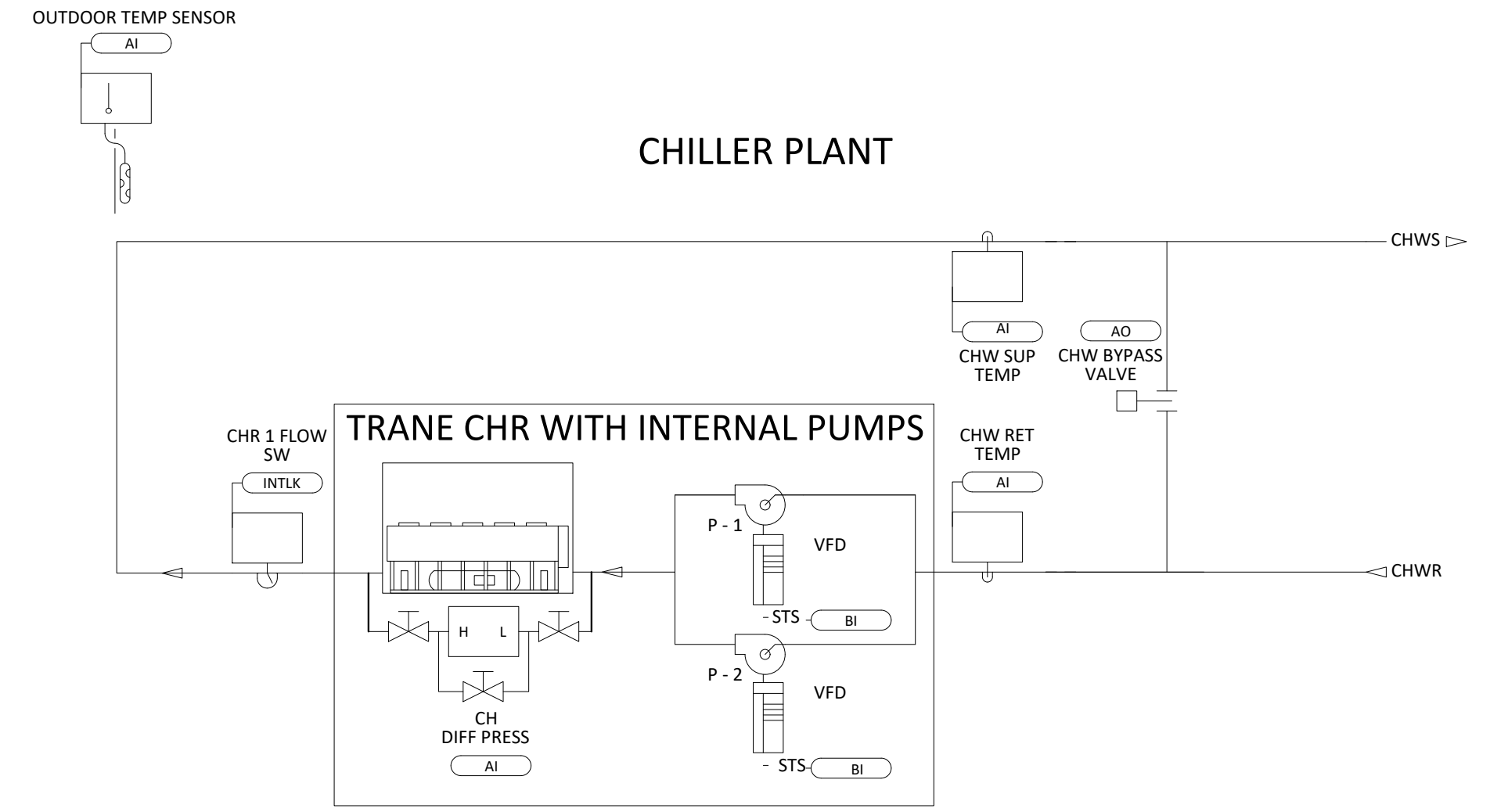

CHILLER PLANT SEQUENCE OF OPERATIONS:
SYSTEM GENERAL DESCRIPTION: THE CHILLED WATER SYSTEM CONSISTS OF THE FOLLOWING:
ONE (1) CHILLER AND TWO (2) CHILLED WATER PUMPS: ONE (1) PRIMARY AND ONE (1) STANDBY

CHILLER - RUN CONDITIONS: THE PRIMARY CHILLER SHALL BE ENABLED TO RUN WHENEVER:
- A DEFINABLE NUMBER OF CHILLED WATER COILS NEED COOLING
- AND THE OUTSIDE AIR TEMPERATURE IS GREATER THAN 54° (ADJ.).
WHEN ENABLED, THE CHILLER, VIA ITS INTERNAL CONTROLS, SHALL MAINTAIN THE CHILLED WATER SUPPLY TEMPERATURE AT SETPOINT.

CHILLED WATER BYPASS VALVE CONTROL: THE BAS CONTROLLER SHALL MONITOR THE EVAPORATOR DIFFERENTIAL PRESSURE OF THE CHILLER. WHEN THE PRESSURE OF THE OPERATING CHILLER INDICATES A LOW PRESSURE (FLOW), THE BAS CONTROLLER SHALL CONTROL THE ANALOG SIGNAL THAT IS SENT TO THE CHILLED WATER BYPASS VALVE TO MAINTAIN THE MINIMUM PRESSURE (FLOW) SETPOINT (ADJ.) OF THE CHILLER.

CHILLED WATER PUMP STATUS: THE BAS CONTROLLER SHALL DETECT CHILLED WATER PUMP RUN STATUS BY A CURRENT SWITCH.

CHILLED WATER PUMP PRIMARY/STANDBY (BY CHILLER INTERNAL CONTROLS): THE CHILLED WATER PUMP PRIMARY/STANDBY SEQUENCE SHALL BE ROTATED ON A WEEKLY SCHEDULE. THE SEQUENCE SHALL BE BASED ON CALCULATED RUN TIME WITH THE PUMP HAVING THE LEAST RUN TIME AS PRIMARY PUMP AND THE PUMP WITH THE HIGHEST RUN TIME WILL BE THE STANDBY PUMP. FROM THE BAS OR WITH TRACER TU AN OPERATOR SHALL BE ABLE TO MANUALLY CHANGE THE PRIMARY/STANDBY SEQUENCE.

CHILLED WATER PUMP FAILURE (BY CHILLER INTERNAL CONTROLS): IF THE PRIMARY START/STOP RELAY IS ENABLED AND THE CURRENT SWITCH STATUS IS OFF FOR MORE THAN 30 SECONDS (ADJ.), THE BAS CONTROLLER SHALL ANNUNCIATE A CHILLED WATER PUMP FAILURE ALARM TO THE BAS AND START THE STANDBY PUMP.

NETWORK

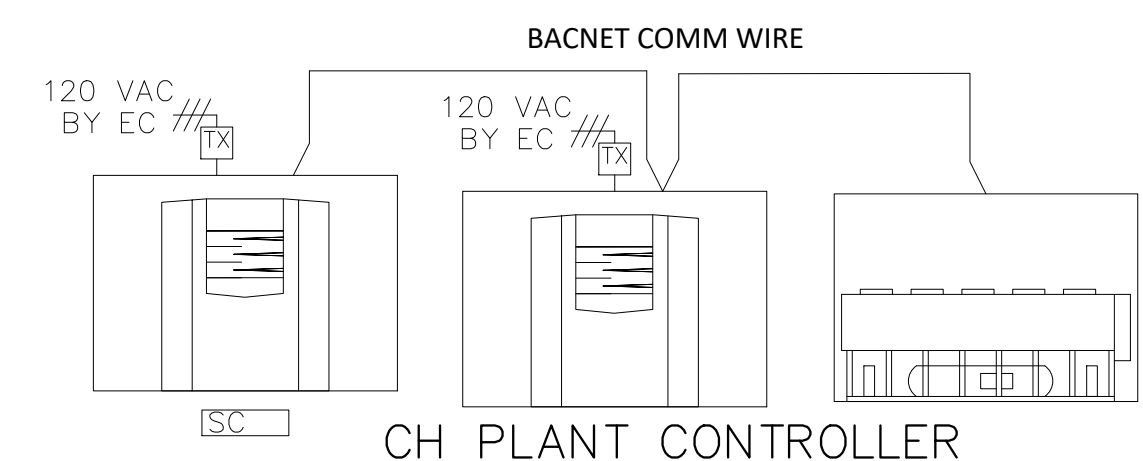

GENERAL NOTES:
- SC SHALL BE WEB-ENABLED. SC IP ADDRESS BY OTHERS
- SPACE SENSORS LOCATED AS PER PLANS.
- DIV.16 ELECTRICAL CONTRACTOR TO PROVIDE 120/277 VAC POWER TO ALL FIELD CONTROLLERS
- CHILLER SHALL BE PROVIDED WITH BACNET COMMUNICATION CARD BY MANUFACTURER

BASIS OF DESIGN TRANE (954) 499-6900

CITY OF PEMBROKE PINES - ART COLONY - STUDIO 18
UPGRADE HVAC SYSTEM
1101 POINCIANA DRIVE
PEMBROKE PINES, FL. 33026

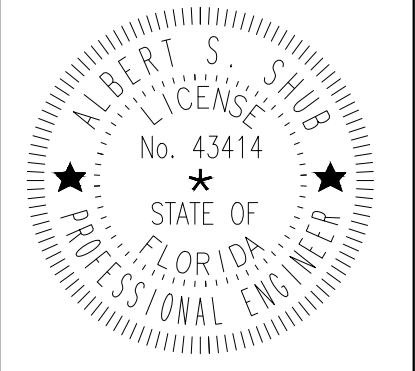

JOB NUMBER: 25025
ALBERT SHUB
PE# 0043414 M.E.
E80003662
FLORIDA ENGINEERING SERVICES
MECHANICAL AND ELECTRICAL
ENGINEERS



drawn by: AS
date: 09-09-2025

sheet no:

M-2

project:

EXISTING FREE STANDING SERVICE No.1 OF 2 (FOR REFERENCE ONLY)
 EXISTING ELECT. METER M#1 OF 1

NEW THWN CU 4#800 MCM 4" PVC TO REPLACE EXISTING SERVICE No.2 FEEDER.
 NEW NEW EXIST. ELECT. M#2 M#1 METER OF 2 OF 2

NEW WEATHER PROOF/WEATHER RESISTANT GFCI, 120V DUPLEX RECEPTACLE AT FREE STANDING STRUCTURE FOR CHILLER CONTROLLER.

NEW NEMA 4X, 400A, 3P, 208V DISCONNECT SWITCH W/300A FUSES AT NEW FREE STANDING UNISTRUT STRUCTURE.

NEW UNDERGROUND THWN CU 3#350 MCM & 1#4 CU (GND) 3" PVC

EXISTING 120/208V FPL PAD MOUNTED TRANSFORMER

NEW UNDERGROUND THWN CU 3#350 MCM & 1#4 CU (GND) 3" PVC

AC-2 @ WP/WR

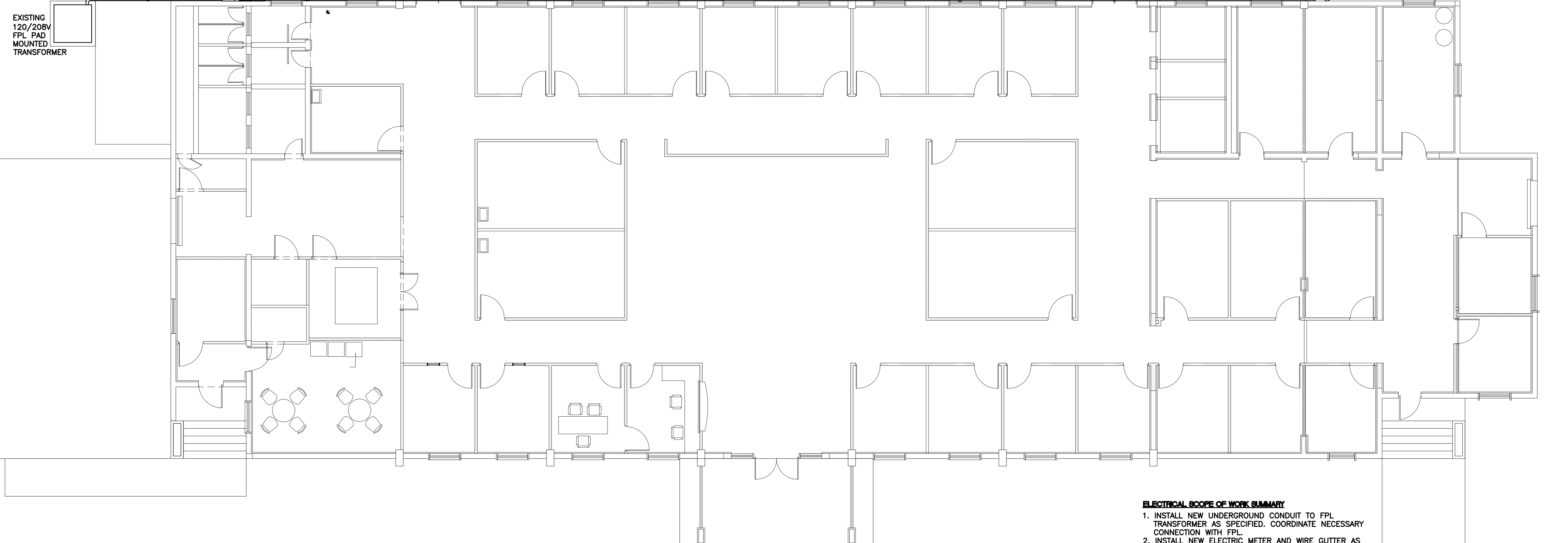

EXISTING BUILDING FLOOR PLAN WITH ELECTRICAL SERVICE FOR NEW HVAC EQUIPMENT
 SCALE: 1/8" = 1'-0"

- ELECTRICAL SCOPE OF WORK SUMMARY**
1. INSTALL NEW UNDERGROUND CONDUIT TO FPL TRANSFORMER AS SPECIFIED. COORDINATE NECESSARY CONNECTION WITH FPL.
 2. INSTALL NEW ELECTRIC METER AND WIRE GUTTER AS SPECIFIED.
 3. INSTALL NEW SERVICE MAIN #2 OF 2 AND WIRING AS SPECIFIED.
 4. INSTALL NEW GROUNDING BAR AND WIRING AS SPECIFIED.
 5. INSTALL NEW UNDERGROUND CONDUIT AND WIRING TO CHILLER PAD LOCATION AS SPECIFIED.
 6. INSTALL NEW DISCONNECT SWITCH AT CHILLER PAD AND MAKE ALL FINAL CONNECTIONS TO CHILLER AS SPECIFIED.

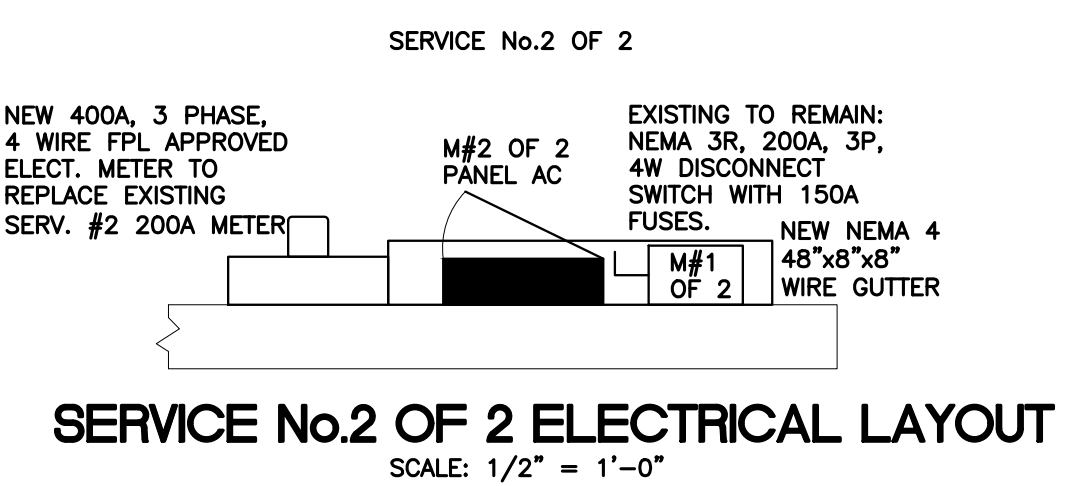

SERVICE No.2 OF 2 ELECTRICAL LAYOUT
 SCALE: 1/2" = 1'-0"

revisions:

CITY OF PEMBROKE PINES - ART COLONY - STUDIO 18
UPGRADE HVAC SYSTEM
 1101 POINCIANA DRIVE
 PEMBROKE PINES, FL. 33026

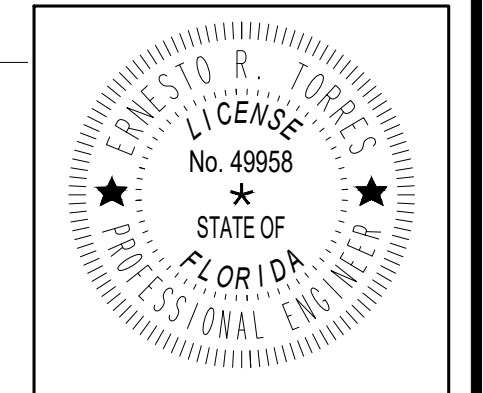

JOB NUMBER: 25025
 ERNESTO R. TORRES
 PE# 0049958 E.E.
 EB0003882
 FLORIDA ENGINEERING SERVICES
 MECHANICAL AND ELECTRICAL
 ENGINEERS

drawn by: ERT
 date: 09-09-2025

sheet no:
E-1
 project:

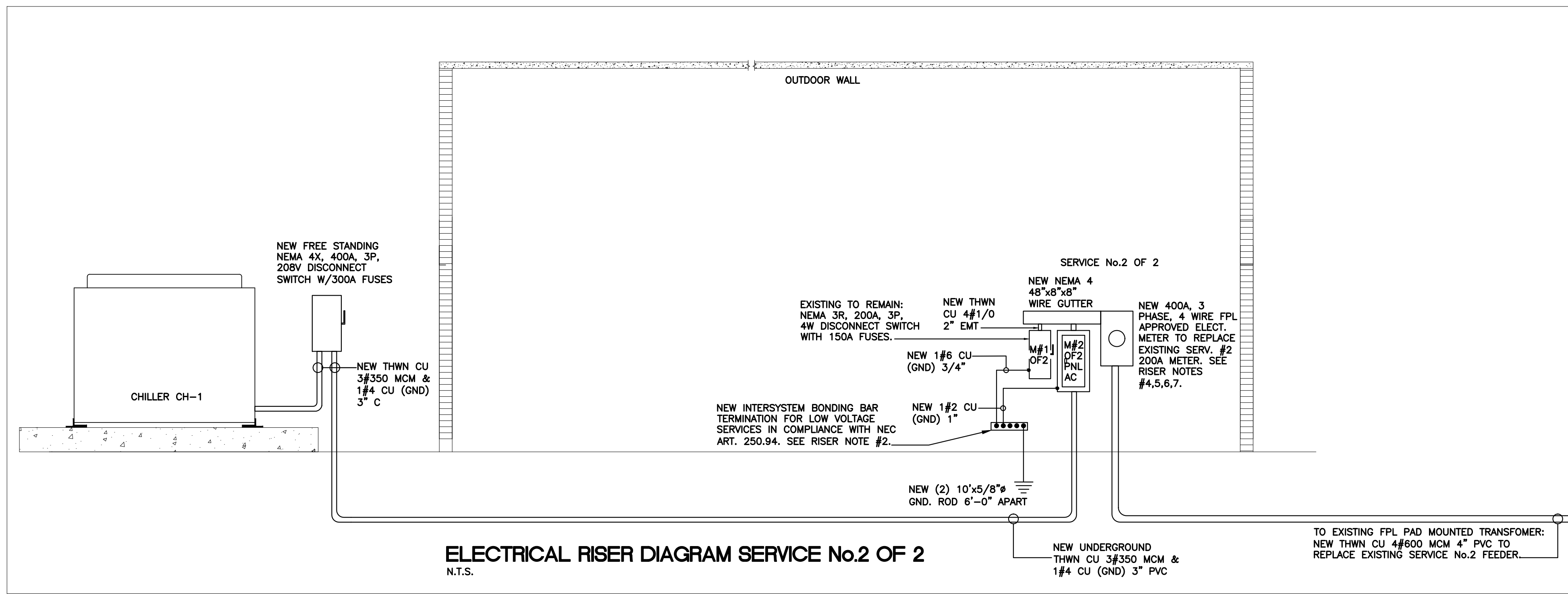

ELECTRICAL RISER DIAGRAM SERVICE No.2 OF 2
N.T.S.

SERVICE No.2 OF 2 CALCULATION

LOAD	AMPS			
	A	B	C	NEUT.
MAIN #1 (EXISTING PANEL C)	84	84	84	84
MAIN #2 (NEW PANEL AC)	198	198	198	1
TOTAL AMPS.	282	282	282	85

NEW SERVICE REQUIRED:
400A, 3P, 4W, UNDERGROUND
THWN CU 4#600 MCM 4" PVC.
COORDINATE W/FPL FIELD
REPRESENTATIVE BEFORE DOING
ANY WORK.

BUILDING SERVICE ENTRANCE CALCULATION (FOR FPL TRANSFORMER LOAD)

LOAD	AMPS			
	A	B	C	NEUT.
SERVICE No.1 OF 2 (AS PER BASE BUILDING PERMIT)	343	343	343	163
UPGRADED SERVICE No.2 OF 2	282	282	282	85
TOTAL AMPS.	625	625	625	248

GENERAL ELECTRICAL NOTES

- ALL WORK SHALL CONFORM WITH ALL LOCAL, STATE, FEDERAL ORDINANCES AND BUILDING CODES GOVERNING THE INSTALLATION OF THE ELECTRICAL SYSTEM TO INCLUDE BUT NOT LIMITED TO FBC 2023, NEC 2020, NFPA 72 2019, NFPA 99 (NFPA 101 2021). IF WORK AS LAD OUT, INDICATED OR SPECIFIED IS CONTRARY TO OR CONFLICTS WITH LOCAL ORDINANCES, BUILDING CODES & REGULATIONS, THE CONTRACTOR SHALL REPORT IN WRITING TO THE ARCHITECT/ENGINEER BEFORE SUBMITTING A BID. THE ARCHITECT/ENGINEER WILL THEN ISSUE INSTRUCTIONS AS HOW TO PROCEED.
- THE DRAWING ARE TO BE CONSIDERED DIAGRAMMATIC, NOT NECESSARILY SHOWING IN DETAIL OR TO SCALE ALL OF THE MINOR ITEMS. UNLESS SPECIFIC DIMENSIONS ARE SHOWN, THE STRUCTURAL AND SITE CONDITIONS SHALL GOVERN THE EXACT LOCATIONS. CONTRACTOR SHALL FOLLOW DRAWINGS IN LAYING OUT WORK. CHECK DRAWINGS OF ALL TRADES TO VERIFY SPACES IN WHICH WORK WILL BE INSTALLED AND MAINTAIN SPACE CONDITIONS AT ALL POINTS. WHERE SPACE CONDITIONS APPEAR INADEQUATE, OWNER REP./ENGINEER SHALL BE NOTIFIED BEFORE PROCEEDING WITH INSTALLATION. THIS CONTRACTOR SHALL, WITHOUT EXTRA CHARGE, MAKE FIELD MODIFICATION IN LAYOUT AS NEEDED TO PREVENT CONFLICT WITH WORK OF VARIOUS TRADES OR FOR PROPER EXECUTION OF THE WORK.
- EXAMINE ALL DRAWINGS CAREFULLY PRIOR TO SUBMITTING A BID. CONTRACTOR WILL BE REQUIRED TO FURNISH, INSTALL AND/OR CONNECT WITH APPROPRIATE SERVICES ALL ELECTRICAL ITEMS SHOWN ON THESE DRAWINGS WITHOUT ADDITIONAL EXPENSE TO THE OWNER. IF DISCREPANCIES, CONFLICTS, INTERFERENCES OR OMISSIONS OCCUR BETWEEN DRAWINGS, NOTIFY IN WRITING THE OWNER REP./ENGINEER IN AMPLIE TIME TO PERMIT REVISIONS BEFORE THE BIDS ARE SUBMITTED.
- VERIFY SERVICE CHARACTERISTICS, LOCATION AND CONNECTION WITH ELECTRIC UTILITY COMPANY. PERFORM ALL WORK RELATED TO SERVICE IN STRICT ACCORDANCE WITH UTILITY CO. STANDARDS AND REQUIREMENTS.
- INSTALL MATERIALS AND EQUIPMENT IN A NEAT AND FIRST CLASS WORKMANLIKE MANNER. THE OWNER RESERVES THE RIGHT TO DIRECT REMOVAL AND REPLACEMENT OF ITEM WHICH, IN HIS OPINION, DO NOT PRESENT A NEAT AND WORKMANLIKE APPEARANCE. REMOVAL AND REPLACEMENT IS TO BE DONE IMMEDIATELY WHEN DIRECTED BY THE OWNER IN WRITING, AT THE SOLE EXPENSE OF CONTRACTOR.
- START OF WORK BY CONTRACTOR SHALL BE CONSIDERED AS ACCEPTANCE BY HIM OF ALL CLAIMS OR QUESTIONS AS TO SUITABILITY OF THE WORK OF OTHER TRADES OR OTHER CONTRACTORS TO RECEIVE HIS WORK. THIS CONTRACTOR SHALL REMOVE AND REPLACE, AT HIS EXPENSE, ALL ELECTRICAL WORK WHICH MAY HAVE TO BE REMOVED BECAUSE OF INTERFERENCE WITH OTHER TRADES.
- THIS CONTRACTOR SHALL OBTAIN AND PAY ALL INSURANCE, FEES, PERMITS ASSOCIATION DUES, ROYALTIES, AND TAXES OF WHATEVER NATURE SHALL APPLY TO THIS WORK. HE SHALL ALSO PAY ALL INSPECTION FEES AS MAY BE REQUIRED BY LAW OR ORDINANCE AND SHALL KEEP THE OWNER HARMLESS FROM ANY DAMAGE AND EXPENSE ARISING FROM ANY VIOLATION OF THE LAWS, RULES OR ORDINANCES.
- ALL WIRE SHALL BE COPPER TYPE THWN IN EMT/PVC RACEWAYS.
- WIRE UP COMPLETE THE NEW HVAC EQUIPMENT AS DIRECTED BY HVAC CONTRACTOR. CONTROL WIRING SHALL BE SEPARATE RACEWAY FROM POWER WIRING.
- NOT USED.
- PROVIDE MEANS "FURNISH AND INSTALL".
- COORDINATE WORK WITH WORK OF OTHER TRADES TO AVOID ALL CONFLICTS.
- DO A COMPLETE JOB, EVERYTHING CONNECTED, READY FOR USE.
- IDENTIFY CLEARLY ON A TYPE WRITTEN FORM ALL CIRCUITS AND EQUIPMENT TO CORRESPOND WITH THE PLANS AND PANELS SCHEDULE AND ATTACH INSIDE THE PERTAINING PANEL.
- RACEWAYS:** ALL EXPOSED RACEWAYS AT OUTDOOR WALLS AND INTERIOR SPACES TO BE EMT. ALL NEW UNDERGROUND RACEWAYS TO BE PVC SCHEDULE 40.
- SHOP DRAWINGS:** THIS CONTRACTOR SHALL FURNISH THE ENGINEER WITH SHOP DRAWINGS OF EQUIPMENT PRIOR TO PURCHASE FOR APPROVAL.
- TESTING:** THE CONTRACTOR SHALL TEST ALL WORK AND EQUIPMENT AS DIRECTED BY THE ARCHITECT AND BY AUTHORITIES HAVING JURISDICTION, FURNISHING ALL EQUIPMENT AND NECESSARY PERSONNEL AND ELECTRIC POWER. THE ENTIRE INSTALLATION SHALL BE TESTED FOR SHORTS, GROUNDS AND OPEN CIRCUITS, AND ALL DEFECTS SHALL BE DEMONSTRATED TO BE IN PROPER WORKING AND OPERATING CONDITION TO THE COMPLETE SATISFACTION OF THE ENGINEER.
- GUARANTEES:** ALL EQUIPMENT AND MATERIALS SHALL BE GUARANTEED FOR ONE YEAR AFTER THE DATE OF ACCEPTANCE BY OWNER.
- AT COMPLETION OF JOB THE ELECTRICAL CONTRACTOR SHALL GIVE THE OWNER AN AS-BUILT SET OF REPRODUCIBLE COPIES SHOWING THE EXACT ELECTRICAL INSTALLATION.
- BEFORE BIDDING THE JOB THE ELECTRICAL CONTRACTOR SHALL VISIT THE SITE AND BECOME FAMILIAR WITH ALL EXISTING CONDITIONS.
- CONTRACTOR SHALL PROVIDE TO THE BUILDING OWNER WITHIN 30 DAYS AFTER THE DATE OF ACCEPTANCE, RECORD DRAWINGS OF THE ACTUAL INSTALLATION INCLUDING A SINGLE-LINE DIAGRAM OF THE BUILDING ELECTRICAL DISTRIBUTION SYSTEM AND FLOOR PLANS INDICATING LOCATION AND AREA SERVED FOR ALL DISTRIBUTION IN FULL COMPLIANCE WITH FBC EC 4405.6.4.1.
- CONTRACTOR SHALL PROVIDE TO THE BUILDING OWNER AN OPERATING MANUAL AND MAINTENANCE MANUAL, INCLUDING SUBMITTAL DATA STATING EQUIPMENT RATING AND SELECTED OPTIONS FOR EACH PIECE OF EQUIPMENT REQUIRING MAINTENANCE, OPERATION MANUALS AND MAINTENANCE MANUALS FOR EACH PIECE OF EQUIPMENT REQUIRING MAINTENANCE WITH CLEARLY IDENTIFIED REQUIRED ROUTINE MAINTENANCE ACTIONS AND NAMES AND ADDRESSES OF AT LEAST ONE QUALIFIED SERVICE AGENCY IN FULL COMPLIANCE WITH FBC EC 4405.6.4.2.

- RISER NOTES :**
- ALL WIRE SHALL BE COPPER THWN OR AS OTHERWISE NOTED ON THESE PLANS
 - NEW GROUND SYSTEM TO TWO 10'-0" LONG x 5/8" COPPER CLAD GROUND ROD 6'-0" APART.
 - ALL EQUIPMENT INTERRUPTING CAPACITIES SHALL COMPLY WITH FPL PROVIDED FAULT CURRENT IN FULL COMPLIANCE WITH NEC 110.9. THE ELECTRICAL CONTRACTOR SHALL VERIFY AIC RATING OF THE EQUIPMENT WITH FAULT CURRENT INFORMATION PROVIDED BY THE POWER COMPANY BEFORE ORDER THE ELECTRICAL EQUIPMENT. ELECTRICAL CONTRACTOR SHALL PERMANENTLY MARK IN THE FIELD, WITH LEGIBLE LETTERS, THE MAXIMUM AVAILABLE FAULT CURRENT PROVIDED BY FPL AT THE NEW SERVICE ENTRANCE MAIN CIRCUIT BREAKER AT NEW PANEL AC & EXISTING DISC. SWITCH MAIN No.1 OF 1, TO COMPLY WITH NEC 110.24.
 - PROVIDE PERMANENT PLAQUE AS PER NEC 230.2 AT SERVICE ENTRANCE No.1 & No.2 LOCATIONS.
 - NEW SERVICE No.2 ELECTRICAL METER, NEW PANEL "AC" AND NEW DISCONNECT SWITCHES SHALL BE INSTALLED ABOVE FLOOD CRITERIA.
 - EXISTING SERVICE No.2 ELECTRICAL METER SERVING EXISTING PANEL "C" (KILNS EQUIPMENT) SHALL BE DISCONNECTED FROM EXISTING FPL TRANSFORMER AND FROM MAIN DISCONNECT SWITCH No.1. ALL ASSOCIATED WIRING SHALL BE REMOVED AND EXISTING CONDUIT ABANDONED.
 - ELECTRICAL CONTRACTOR SHALL COORDINATE WITH THE CITY OF PEMBROKE PINES & FPL FIELD REPRESENTATIVE THE TEMPORARY TURNING OFF OF THE FPL TRANSFORMER SERVING THE EXISTING BUILDING DURING THE DISCONNECTION OF THE SERVICE No.2 ELECTRICAL METER AND THE CONNECTION OF THE NEW UPGRADED METER AS SHOWN ON THESE DRAWINGS.
 - EXISTING HVAC EQUIPMENT (AHU-1, AHU-2 AND THEIR ASSOCIATED ELECTRICAL DUCT HEATER) SHALL REMAIN CONNECTED TO EXISTING BUILDING PANELS AND ARE NOT PART OF THIS ELECTRICAL PERMIT.

NEW SERVICE ENTRANCE NEMA 4X PANELBOARD WITH FEED THRU LUGS AND INTEGRATED SURGE PROTECTION DEVICES (SERVICE No.2 OF 2, MAIN No.2 OF 2)

PANEL	AMPS	VOLTAGE	CIRCUITS	WIRE	PHASE	MAIN/AIC	MOUNTING	LOCATION	CATALOG NUMBER				
AC	400	120/208	30	4	3	+300A/65KAIC/SE SERIES RATED	SURFACE	OUTDOOR	NEMA 4X PANELBOARD				
CKT. NO.	COND. INCH	CKT BKR POLE	AMPS	SERVING	WATTS	CKT. NO.	COND. INCH	CKT BKR POLE	AMPS	SERVING	WATTS		
1	-	-	-	SPACE	-	2	10	3/4	1	20	NEW GFCI SERV. RECEPT.	360	
3	-	-	-	SPACE	-	4	10	3/4	1	20	NEW CHILLER CONTROLLER	300	
5	-	-	-	SPACE	-	6	-	-	-	SPACE	-	-	
7	-	-	-	SPACE	-	8	-	-	-	SPACE	-	-	
9	-	-	-	SPACE	-	10	-	-	-	SPACE	-	-	
11	-	-	-	SPACE	-	12	-	-	-	SPACE	-	-	
13	-	-	-	SPACE	-	14	-	-	-	SPACE	-	-	
15	-	-	-	SPACE	-	16	-	-	-	SPACE	-	-	
17	-	-	-	SPACE	-	18	-	-	-	SPACE	-	-	
19	-	-	-	SPACE	-	20	-	-	-	SPACE	-	-	
21	-	-	-	SPACE	-	22	-	-	-	SPACE	-	-	
23	-	-	-	SPACE	-	24	-	-	-	SPACE	-	-	
25	-	-	-	SPACE	-	26	-	-	-	SPACE	-	-	
27	-	-	-	SPACE	-	28	-	-	-	SPACE	-	-	
29	-	-	-	SPACE	-	30	-	-	-	SPACE	-	-	
TOTAL						0	TOTAL						660
LINE CALCULATIONS					WATTS	TOTAL AMPS	NEUTRAL CALCULATIONS					WATTS	TOTAL AMPS
CONTINUOUS LOAD					0	LINE	CONTINUOUS LOAD					0	NEUTRAL
+ 25 % OF CONTINUOUS LOAD					0		+ 25 % OF CONTINUOUS LOAD					0	
+ NON-CONTINUOUS LOAD					71280	198	+ NON-CONTINUOUS LOAD					660	2
TOTAL					71280		TOTAL					660	

FEEDER THWN CU: NEW 4#350 MCM CU 3" EMT
SIEMENS, GENERAL ELECTRIC OR SQUARE-D WILL BE APPROVED. CATALOG NUMBER SHOWN: SIEMENS

+ PANEL SHALL BE PROVIDED WITH FEED THRU LUGS TO FEED NEW HVAC CHILLER CH-1. PANEL MAIN CIRCUIT BREAKER IS THE REQUIRED OVERCURRENT PROTECTION OF CHILLER CH-1.

ELECTRICAL LEGEND

- DISCONNECT SWITCH
- ELECTRICAL METER
- ELECTRICAL PANEL
- WP/WR NEW 20A, 120V, GFCI, WEATHER PROOF/WEATHER RESISTANT DUPLEX RECEPTACLE

revisions:

CITY OF PEMBROKE PINES - ART COLONY - STUDIO 18
UPGRADE HVAC SYSTEM
1101 POINCIANA DRIVE
PEMBROKE PINES, FL. 33026

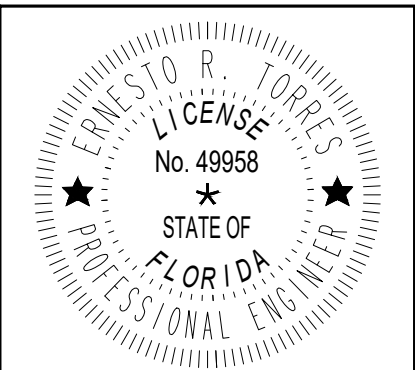

JOB NUMBER: 25025
ERNESTO R. TORRES
PE# 0049958 E.E.
E80003882
FLORIDA ENGINEERING SERVICES
MECHANICAL AND ELECTRICAL
ENGINEERS

drawn by: ERT
date: 09-09-2025
sheet no:

E-2

project:



CONSTRUCTION AGREEMENT
BETWEEN THE CITY OF PEMBROKE PINES
AND {---Company Name---}

THIS AGREEMENT (“Agreement”), dated _____, is entered into by and between:

CITY OF PEMBROKE PINES, a municipal corporation of the State of Florida with a business address of **601 City Center Way, Pembroke Pines, Florida 33025** hereinafter referred to as "CITY",

and

{---Company Name---}, {---Corporation Type---}, as listed with the Florida Division of Corporations, authorized to do business in the State of Florida, and with a business address of {---Street1---} {---Street2---}, {---City---}, {---State/Province---} {---Postal Code---} (hereinafter referred to as the “CONTRACTOR”). CITY and CONTRACTOR may hereinafter be referred to collectively as the "Parties."

WITNESSETH:

In consideration of the mutual terms and conditions, promises, covenants and payments hereinafter set forth, CITY and CONTRACTOR agree as follows:

ARTICLE 1
PREAMBLE

In order to establish the background, context and form of reference for this Agreement, and to generally express the objectives and intentions of the respective Parties herein, the following statements, representations, and explanations shall be accepted as predicates for the undertakings and commitments included within the provisions which follow, and may be relied upon by the Parties as essential elements of the mutual considerations upon which this Agreement is based.

1.1 On {---Solicitation Advertisement Date---}, the CITY advertised its notice to bidders of the CITY's desire to hire a firm to {---Solicitation Service Description---} as more particularly described in **Exhibit "A"** attached hereto and by this reference made a part hereof, for the said bid entitled:

{---Solicitation Type Abbreviation---} # {---Solicitation Number---}
“{---Solicitation Title---}”

1.2 On {---Bid Opening Date---}, the bids were opened at the offices of the City Clerk.



1.3 On _____, the CITY awarded the bid to CONTRACTOR and authorized the proper CITY officials to negotiate and enter into an agreement with CONTRACTOR to render the services more particularly described herein below.

1.4 Negotiations pertaining to the services to be performed by the CONTRACTOR were undertaken and this Agreement incorporates the results of such negotiation.

ARTICLE 2

SERVICES AND RESPONSIBILITIES

2.1 CONTRACTOR hereby agrees to perform the services for the {---**Solicitation Service Description**---}, at {---**Location Address**---} ("Property") as more particularly described in, and in accordance with the CITY's "{---**Solicitation Type Abbreviation**---} # {---**Solicitation Number**---}", attached hereto and made a part hereof as **Exhibit "A"** and CONTRACTOR's response thereto, attached hereto and made a part hereof as **Exhibit "B"**. CONTRACTOR agrees to perform all services required pursuant to this Agreement, the Sealed Bid Package, Addenda to this Agreement, and Commission award complete with proposal form.

2.2 CONTRACTOR shall furnish all services, labor, equipment, and materials necessary and as may be required in the performance of this Agreement, except as otherwise specifically provided for herein, and all work performed under this Agreement shall be done in a professional manner.

2.3 CONTRACTOR shall supervise the work force to ensure that all workers conduct themselves and perform their work in a safe and professional manner. CONTRACTOR shall comply with all OSHA safety rules and regulations in the operation of equipment and in the performance of the work. CONTRACTOR shall at all times have a competent field supervisor available to enforce these policies and procedures at the CONTRACTOR's expense.

2.4 CONTRACTOR shall provide CITY with seventy-two (72) hours written notice prior to the beginning of work under this Agreement and prior to any schedule change with the exception of changes caused by inclement weather.

2.5 CONTRACTOR hereby represents to CITY, with full knowledge that CITY is relying upon these representations when entering into this Agreement with CONTRACTOR, that CONTRACTOR has the professional expertise, experience and manpower to perform the services to be provided by CONTRACTOR pursuant to the terms of this Agreement.

2.6 CONTRACTOR hereby represents to CITY that CONTRACTOR is properly licensed by the applicable federal, state, and local agencies to provide the services under this Agreement. Furthermore, CONTRACTOR agrees to maintain such licenses during the term of this Agreement. If CONTRACTOR's license is revoked, suspended, or terminated for any reason by any governmental agency, CONTRACTOR shall notify the CITY immediately.

2.7 CONTRACTOR shall comply with any and all Federal, State, and local laws and regulations now in effect, or hereinafter enacted during the term of this Agreement, which are applicable to CONTRACTOR, its employees, agents or subcontractors, if any, with respect to the



work and services described herein. A violation of any federal, state, or local law or regulation may be cause for breach, allowing the CITY to terminate this Agreement.

2.8 CONTRACTOR shall gain prior written approval from the CITY prior to engaging any subconsultants, subcontractors, or other professional associates to perform in connection with this Agreement. Any subcontract with a subcontractor or subconsultant shall afford to the CONTRACTOR rights against the subcontractor or subconsultant which correspond to those rights afforded to the CITY against the CONTRACTOR herein, including but not limited to those rights of termination as set forth herein. No reimbursement shall be made to the CONTRACTOR for any subconsultants that have not been previously approved by the CITY for use by the CONTRACTOR.

2.9 **Return of Keys.** Upon completion of services rendered or termination of this agreement, CONTRACTOR must promptly return to CITY all CITY keys and/or access cards. By agreeing herein, CONTRACTOR understands that any loss or failure to return a CITY key shall subject CONTRACTOR to the costs associated with key replacement and/or re-keying. For keys unlocking several doors, replacement and re-keying costs can be substantial. In case of failure to return a key and failure to pay for key replacement and/or lock re-keying, CONTRACTOR understands that CITY shall enforce by all legal means its right to repayment for all costs incident to key replacement and/or lock re-keying.

ARTICLE 3

TIME OF COMMENCEMENT AND SUBSTANTIAL COMPLETION

3.1 The work to be performed under this Agreement shall be commenced after CITY execution of the Agreement and not later than ten (10) days after the date that CONTRACTOR receives CITY's Notice to Proceed. The work shall be completed within {---Number of Days to Complete Project in Words---} {---Number of Days to Complete Project---} calendar days from issuance of CITY's Notice to Proceed, subject to any permitted extensions of time pursuant to this Agreement and any amendments and/or addenda thereto. For the purposes of this Agreement, the term "completion" shall mean the satisfactory completion and final inspection of the Property by the CITY.

3.2 During the pre-construction portion of the work hereunder, the Parties agree to work diligently and in good faith in performing their obligations hereunder, so that all required permits for the construction portion of the work may be obtained. In the event that any delays in the pre-construction or construction portion of the work occur, despite the diligent efforts of the Parties hereto, and such delays are the result of force majeure or are otherwise outside of the control of either party hereto, then the Parties shall agree on an equitable extension of the time for substantial completion hereunder and any resulting increase in general condition costs.

3.3 In the event that CONTRACTOR abandons this Agreement or causes it to be terminated, CONTRACTOR shall indemnify CITY against any loss pertaining to this termination up to a maximum of the full contracted fee amount. All finished or unfinished documents, data, studies, surveys, and reports prepared by CONTRACTOR shall become the property of CITY and shall be delivered by CONTRACTOR to CITY.



3.4 **Termination for Convenience.** This Agreement may be terminated by CITY for convenience, upon providing **{---Termination for Convenience---** of written notice to CONTRACTOR for such termination in which event CONTRACTOR shall be paid its compensation for services performed to termination date, including services reasonably related to termination. In the event that CONTRACTOR abandons this Agreement or causes it to be terminated, CONTRACTOR shall indemnify CITY against loss pertaining to this termination.

3.5 **Default by CONTRACTOR.** In addition to all other remedies available to CITY, this Agreement shall be subject to cancellation by CITY for cause, should CONTRACTOR neglect or fail to perform or observe any of the terms, provisions, conditions, or requirements herein contained, if such neglect or failure shall continue for a period of **thirty (30) calendar days** after receipt by CONTRACTOR of written notice of such neglect or failure.

ARTICLE 4 **COMPENSATION AND METHOD OF PAYMENT**

4.1 CITY agrees to compensate CONTRACTOR for all services performed under this Agreement by CONTRACTOR for work that has been completed, inspected and properly invoiced. The total compensation for all services shall not exceed **{---Request Amount Written---** (**{---Request Amount Numerical---**) which includes an owner's contingency fee in the amount of **{---Contingency Fee in Words---** (**{---Contingency Fee Amount---**) and an amount towards the payment and performance bond equal to _____.

4.1.1 This contingency or allowance authorizes the CITY to execute change orders up to the amount of the contingency without the need to obtain additional Commission approval. In addition, CITY shall utilize the owner's contingency to reimburse CONTRACTOR for the related permit, license, impact or inspection fees. Payments will be made to CONTRACTOR based on the actual cost of permits upon submission of paid permit receipts. **It is hereby understood and agreed that the CONTRACTOR shall not expend any dollars in connection with the owner's contingency or allowance without the expressed prior written approval of the CITY's authorized representative.** Any owner's contingency funds or allowance that have not been utilized at the end of the project will remain with the CITY, the CONTRACTOR shall only be paid for the proposed project cost as approved by the City Commission along with any owner contingency expenses or allowances that were approved by the CITY's authorized representative. If the permit fees exceed the Owner's Contingency indicated, CITY will reimburse the contractor the actual amount of the permit fees required for project completion.

4.1.2 The total compensation amount may not be exceeded without a written amendment to this Agreement. A retainage of five percent (5%) will be deducted from monthly payments until the project is complete. Retainage monies will be released upon satisfactory completion and final inspection of the work. Invoices must bear the project name, project number, bid number and purchase order number. CITY has up to thirty (30) days to review, approve and pay all invoices after receipt. CONTRACTOR shall invoice CITY and provide a written request to CITY to commence the one (1) year warranty period. All necessary Releases and



Affidavits and approval of final payments shall be processed before the warranty period begins.

4.2 **Prompt Payment Act.** All payments shall be governed by the Local Government Prompt Payment Act, as set forth in Part VII, Chapter 218, Florida Statutes.

4.3 **Method of Billing and Payment.** The CITY shall within thirty (30) calendar days, from the date the CITY's Authorized Representative approves the Application for Payment, pay the CONTRACTOR the amount approved by the CITY's Authorized Representative or his/her assignees. Invoices submitted by CONTRACTOR shall include the date of service, services performed, hours spent, location of services, description of the assignment/project, date of completion and any other information reasonable required by the CITY.

Payment will be made to CONTRACTOR at:

{---Company Name---}
{---Payment Street 1---}, {---Payment Street 2---}
{---Payment City---}, {---Payment State/Province---} {---Payment Postal Code---}

ARTICLE 5 WAIVER OF LIENS

Prior to final payment of the amount due under the terms of this Agreement, a final waiver of lien shall be submitted by the CONTRACTOR as well as all suppliers and subcontractors who worked on the project that is the subject of this Agreement. Payment of the invoice and acceptance of such payment by CONTRACTOR shall release CITY from all claims of liability by CONTRACTOR in connection with this Agreement.

ARTICLE 6 WARRANTY

CONTRACTOR warrants the work against defect for a period of one (1) year from the date of completion of work. In the event that defect occurs during this time, CONTRACTOR shall perform such steps as required to remedy the defects. CONTRACTOR shall be responsible for any damages caused by defect to affected area or to interior structure. The one (1) year warranty period does not begin until substantial completion of the entire project, and the subsequent release of any Performance or Payment Bonds, which may be required by the original bid document.

ARTICLE 7 CHANGES IN SCOPE OF WORK

7.1 CITY or CONTRACTOR may request changes that would increase, decrease, or otherwise modify the scope of work, as more specifically described herein. These changes may affect the monthly compensation accordingly. Such changes or additional services must be in accordance with the provisions of the Code of Ordinances of the CITY, and must be contained in a written change order or amendment, executed by the Parties hereto, with the same formality, equality and



dignity herewith prior to any deviation from the terms of this Agreement, including the initiation of any additional or extra work. In no event will the CONTRACTOR be compensated for any work which has not been described either herein or in a separate written change order, amendment or agreement executed by the Parties hereto.

7.2 While requesting changes that would increase, decrease, or otherwise modify the scope of work, CONTRACTOR shall continue work, however, in no event will CONTRACTOR be compensated for any work that has not been described either herein, or by a change order, written amendment or separate written agreement, executed by the parties hereto, with the same formality, equality, and dignity herewith.

ARTICLE 8

PAYMENT & PERFORMANCE BONDS

8.1 Within fifteen (15) calendar days after Notice of Award and in any event prior to commencing work, the CONTRACTOR shall execute and furnish to CITY a Payment Bond and a Performance Bond, each written by a corporate surety, having a resident agent in the State of Florida and having been in business with a record of successful continuous operation for at least five (5) years. The surety shall hold a current certificate of authority from the Secretary of Treasury of the United States as an acceptable surety on federal bonds in accordance with United States Department of Treasury Circular No. 570. If the amount of the bonds exceeds the underwriting limitation set forth in the circular, in order to qualify, the net retention of the surety company shall not exceed the underwriting limitation in the circular and the excess risks must be protected by coinsurance, reinsurance, or other methods, in accordance with Treasury Circular 297, revised September 1, 1978 (31DFR, Section 223.10, Section 223.11). Further, the surety company shall provide CITY with evidence satisfactory to CITY, that such excess risk has been protected in an acceptable manner. The surety company shall have at least the following minimum qualification in accordance with the latest edition of A.M. Best's Insurance Guide, published by Alfred M. Best Company, Inc., Ambest Road, Oldwick, New Jersey 08858:

B+ to A+

8.2 Two (2) separate bonds are required and both must be approved by the CITY. **The penal sum stated in each bond shall be 100% of the project value.** The Performance Bond shall be conditioned upon the CONTRACTOR's performance of the work in the time and manner prescribed in the Agreement. The Payment Bond shall be conditioned upon the CONTRACTOR's promptly making payments to all persons who supply the CONTRACTOR with labor, materials and supplies used directly or indirectly by the CONTRACTOR in the prosecution of the work provided for in this Agreement and shall provide that the surety shall pay the same in the amount not exceeding the sum provided in such bonds, together with interest at the maximum rate allowed by law; and that they shall indemnify and save harmless the CITY to the extent of any and all payments in connection with the carrying out of said Agreement which the CITY may be required to make under the law.

8.3 Pursuant to the requirements of Section 255.05(1)(a), Florida Statutes, it shall be the duty of the CONTRACTOR to record the aforesaid Payment Bond and Performance Bond in the public records of Broward County, and CONTRACTOR shall be responsible for payment of all recording costs.



ARTICLE 9
INDEMNIFICATION

9.1 CONTRACTOR shall indemnify and hold harmless the CITY, its officers, agents, assigns, employees, consultants, separate contractors, any of their subcontractors, and sub-subcontractors from and against claims, demands, or causes of action whatsoever, and the resulting losses, damages, costs and expenses, including but not limited to attorney's fees, including paralegal expenses, liabilities, damages, orders, judgments, or decrees, sustained by the CITY arising out of or resulting from performance of this Agreement, the failure of CONTRACTOR to take out and maintain insurance as required under this Agreement, and any negligent act or omission of CONTRACTOR, its employees, agents, partners, principals, subcontractors, and officers. The CONTRACTOR shall pay all claims and losses in connection therewith and shall investigate and defend all claims, suits or actions of any kind or nature in the name of the CITY, where applicable, including appellate proceedings, and shall pay all costs, judgments, and attorneys' fees which may issue thereon.

9.2 Upon completion of all services, obligations and duties provided for in this Agreement, or in the event of termination of this Agreement for any reason, the terms and conditions of this Article shall survive indefinitely.

9.3 CITY reserves the right to select its own legal counsel to conduct any defense in any such proceeding and all costs and fees associated therewith shall be the responsibility of CONTRACTOR.

9.4 CONTRACTOR shall be liable for any accident, loss, injury or damages to persons and/or property arising out of and/or resulting from CONTRACTOR's performance of the work required by this Agreement.

9.5 Nothing contained herein is intended nor shall be construed to waive CITY's rights and immunities under the common law or Section 768.28, Florida Statutes, as may be amended from time to time.

ARTICLE 10
INSURANCE

10.1 CONTRACTOR expressly understands and agrees that any insurance protection required by this Agreement or otherwise provided by the CONTRACTOR shall in no way limit the responsibility to indemnify, keep and save harmless and defend the CITY or its officers, employees, agents and instrumentalities as herein required.

10.2 CONTRACTOR AND ALL SUBCONTRACTORS, SHALL NOT BE ALLOWED TO commence work under this AGREEMENT until the CONTRACTOR has obtained all insurance required by this Insurance Section, including the purchase of a Policy of Insurance naming the City of Pembroke Pines as an Additional Named Insured, which Insurance Policy and its terms must be agreed to and approved in writing by the Risk Manager for the City of Pembroke Pines



, nor shall any SUBCONTRACTOR be allowed to commence work under this AGREEMENT until the SUBCONTRACTOR complies with the Insurance requirements required by this Insurance Section, including the duty to purchase a Policy of Insurance which names the City of Pembroke Pines as an Additional Named Insured, which Insurance Policy and its terms are agreed to and approved in writing by the Risk Manager for the City of Pembroke Pines.

10.3 Certificates of Insurance, reflecting evidence of the required insurance, shall be filed with the CITY’s Risk Manager prior to the commencement of this Agreement. Policies shall be issued by companies authorized to do business under the laws of the State of Florida. The insurance company shall be rated no less than “A” as to management, and no less than “Class VI” as to financial strength according to the latest edition of Best’s Insurance Guide published by A.M. Best Company.

10.4 Certificates of Insurance shall provide for thirty (30) calendar days’ prior written notice to the CITY in case of cancellation or material changes in the policy limits or coverage states. If the carrier cannot provide thirty (30) calendar days’ notice of cancellation, either the CONTRACTOR or their Insurance Broker must agree to provide notice.

10.5 Insurance shall be in force until all obligations required to be fulfilled under the terms of the Agreement are satisfactorily completed as evidenced by the formal acceptance by the CITY. In the event the insurance certificate provided indicates that the insurance shall terminate and lapse during the period of this Agreement, the CONTRACTOR shall furnish, at least forty-five (45) calendar days prior to the expiration of the date of such insurance, a renewed certificate of insurance as proof that equal and like coverage for the balance of the period of the Agreement and extension thereunder is in effect. The CONTRACTOR shall neither commence nor continue to provide any services pursuant to this Agreement unless all required insurance remains in full force and effect. CONTRACTOR shall be liable to CITY for any lapses in service resulting from a gap in insurance coverage.

10.6 REQUIRED INSURANCE

CONTRACTOR shall be required to obtain all applicable insurance coverage, as indicated below, prior to commencing any work pursuant to this Agreement:

Yes No

10.6.1 Comprehensive General Liability Insurance written on an occurrence basis including, but not limited to: coverage for bodily injury and property damage, personal & advertising injury, products & completed operations, and contractual liability. Coverage must be written on an occurrence basis, with limits of liability no less than:

1. Each Occurrence Limit - \$1,000,000
2. Fire Damage Limit (Damage to rented premises) - \$100,000
3. Personal & Advertising Injury Limit - \$1,000,000
4. General Aggregate Limit - \$2,000,000
5. Products & Completed Operations Aggregate Limit - \$2,000,000

Aggregate Reduction: CONTRACTOR shall advise the CITY in the event any aggregate limits are reduced below the required per-occurrence limit. At its own expense, the



CONTRACTOR will reinstate the aggregate limits to comply with the minimum requirements and shall furnish the CITY with a new certificate of insurance showing such coverage is in force.

Products & Completed Operations Coverage shall be maintained for the later of three (3) years after the delivery of goods/services or final payment under the Agreement. (For Construction projects: Increase to ten (10) years and include a Designated Construction Project(s) General Aggregate Limit) **The City of Pembroke Pines must be shown as an additional insured with respect to this coverage. The CITY’s additional insured status shall extend to any coverage beyond the minimum limits of liability found herein.**

Yes No

10.6.2 Workers’ Compensation and Employers’ Liability Insurance covering all employees, and/or volunteers of the CONTRACTOR engaged in the performance of the scope of work associated with this Agreement. In the case any work is sublet, the CONTRACTOR shall require the subcontractors similarly to provide Workers’ Compensation Insurance for all the latter’s employees unless such employees are covered by the protection afforded by the CONTRACTOR. Coverage for the CONTRACTOR and all subcontractors shall be in accordance with applicable state and/or federal laws that may apply to Workers’ Compensation Insurance with limits of liability no less than:

- 1. Workers’ Compensation: Coverage A – Statutory
- 2. Employers Liability: Coverage B \$500,000 Each Accident
\$500,000 Disease – Policy Limit
\$500,000 Disease – Each Employee

If CONTRACTOR claims to be exempt from this requirement, CONTRACTOR shall provide CITY proof of such exemption for CITY to exempt CONTRACTOR.

Yes No

10.6.3 Comprehensive Auto Liability Insurance covering all owned, non-owned and hired vehicles used in connection with the performance of work under this Agreement, with a combined single limit of liability for bodily injury and property damage no less than:

- 1. Any Auto (Symbol 1)
Combined Single Limit (Each Accident) - \$1,000,000
- 2. Hired Autos (Symbol 8)
Combined Single Limit (Each Accident) - \$1,000,000
- 3. Non-Owned Autos (Symbol 9)
Combined Single Limit (Each Accident) - \$1,000,000

If work under this Agreement includes transportation of hazardous materials, policy shall include pollution liability coverage equivalent to that provided by the latest version of the ISO pollution liability broadened endorsement for auto and the latest version of the ISO Motor Carrier Act endorsement, equivalents or broader language.

Yes No

10.6.3.1 If CONTRACTOR requests reduced limits under a Personal Auto



Liability Policy and it is agreed to by the CITY, coverage shall include Bodily Injury limits of \$100,000 per person/\$300,000 per occurrence and Property Damage limits of \$300,000 per occurrence

Yes No

10.6.4 Umbrella/Excess Liability Insurance in the amount of \$ _____ as determined appropriate by the CITY depending on the type of job and exposures contemplated. Coverage must be follow form of the General Liability, Auto Liability and Employer’s Liability. This coverage shall be maintained for a period of no less than the later of three (3) years after the delivery of goods/services or final payment pursuant to this Agreement. **The City of Pembroke Pines must be shown as an additional insured with respect to this coverage. The CITY’s additional insured status shall extend to any coverage beyond the minimum limits of liability found herein.**

Yes No

10.6.5 Professional Liability/Errors & Omissions Insurance with a limit of liability no less than \$1,000,000 per wrongful or negligent act. This coverage shall be maintained for a period of no less than three (3) years after the delivery of goods/services final payment pursuant to this Agreement. Retroactive date, if any, to be no later than the first calendar day of service to the CITY. *(Limit to align with size and scope of the Agreement and exposure inherent with operation/services being performed. For Construction projects: Increase to ten (10) years.)*

Yes No

10.6.6 Environmental/Pollution Liability insurance shall be required with a limit of no less than \$1,000,000 per wrongful act. Coverage shall include: CONTRACTOR’s completed operations, sudden, accidental and gradual pollution conditions. This coverage shall be maintained for a period of no less than the later of three (3) years after the delivery of goods/services or final payment pursuant to this Agreement. Retroactive date, if any, to be no later than the first calendar day of service to the CITY. *(Limit to align with size and scope of the Agreement and exposure inherent with operation/services being performed. For Construction projects: Increase to ten (10) years).* **The City of Pembroke Pines must be shown as an additional insured with respect to this coverage. The CITY’s additional insured status shall extend to any coverage beyond the minimum limits of liability found herein.**

Yes No

10.6.7 Cyber Liability including Network Security and Privacy Liability with a limit of liability no less than \$1,000,000 per loss. Coverage shall include liability arising from: theft, dissemination and/or use of confidential information stored or transmitted in electronic form, unauthorized access to, use of, or tampering with computer systems, including hacker attacks or inability of an authorized third party to gain access to your services, including denial of service, and the introduction of a computer virus into, or otherwise causing damage to, a customer’s or third person’s computer, computer system, network, or similar computer-related property and the data, software and programs thereon. If vendor is collecting credit card information, it shall cover all PCI breach expenses. Coverage is to include the various state monitoring and state required remediation as well as meet the various state notification requirements. This coverage shall be maintained for a period of no less than the later of three (3) years after delivery of goods/services or final payment of the Agreement. Retroactive date, if any, to be no later than the first calendar day of service to the CITY. **The City of Pembroke Pines must be shown as an additional**



insured with respect to this coverage. The CITY’s additional insured status shall extend to any coverage beyond the minimum limits of liability found herein.

Yes No

10.6.8 Crime Coverage shall include employee dishonesty, forgery or alteration, and computer fraud in an amount of no less than \$1,000,000 per loss. If CONTRACTOR is physically located on CITY’s premises, a third-party fidelity coverage extension shall apply.

Yes No

10.6.9 Garage Liability & Garage-keepers Legal Liability for those that manage parking lots for the CITY or service CITY vehicles. Coverage must be written on an occurrence basis, with limits of liability no less than \$1,000,000 per Occurrence, including products & completed operations. This coverage shall be maintained for a period of no less than the later of three (3) years after the delivery of goods/services or final payment of this Agreement. **The City of Pembroke Pines must be shown as an additional insured with respect to this coverage. The CITY’s additional insured status shall extend to any coverage beyond the minimum limits of liability found herein.**

Yes No

10.6.10 Liquor Liability for those in the business of selling, serving or furnishing of any alcoholic beverages, whether licensed or not, shall carry a limit of liability of no less than \$1,000,000 per occurrence. Coverage shall be maintained for the later of three (3) years after the delivery of goods/services or final payment under the Agreement. **The City of Pembroke Pines must be shown as an additional insured with respect to this coverage. The CITY’s additional insured status shall extend to any coverage beyond the minimum limits of liability found herein.**

Yes No

10.6.11 Sexual Abuse & Molestation for any agreement involving a vulnerable population. Limits shall be no less than \$500,000 per occurrence. This coverage shall be maintained for a period of no less than the later of three (3) years after the delivery of goods/services or final payment of this Agreement. Retroactive date, if any, to be no later than the first calendar day of service to the CITY. *(Limit to align with size and scope of the Agreement and exposure inherent with operation/services being performed.)* **The City of Pembroke Pines must be shown as an additional insured with respect to this coverage. The CITY’s additional insured status shall extend to any coverage beyond the minimum limits of liability found herein.**

Yes No

10.6.12 Builder’s Risk Insurance shall be “All Risk” for one hundred percent (100%) of the completed value of the project that is the subject of this Agreement with a deductible of not more than five percent (5%) for Named Windstorm and \$20,000 per claim for all other perils. The Builder’s Risk Insurance shall include interests of the CITY, the CONTRACTOR and subcontractors of the project. The CONTRACTOR shall include a separate line item for all costs associated with the Builder’s Risk Insurance Coverage for the project. The CITY reserves the right at its sole discretion to utilize the CONTRACTOR’s Builder’s Risk Insurance or for the CITY to purchase its own Builder’s Risk Insurance for the Project. Prior to the CONTRACTOR purchasing the Builder’s Risk insurance for the project, the CONTRACTOR shall allow the CITY the opportunity to analyze the CONTRACTOR’s coverage and determine who shall purchase the coverage.



Should the CITY utilize the CONTRACTOR’s Builder’s Risk Insurance, the CONTRACTOR shall be responsible for all deductibles. If the CITY chooses to purchase the Builder’s Risk Coverage on the project, the CONTRACTOR shall provide the CITY with a change order deduct for all premiums and costs associated with the Builder’s Risk insurance in their schedule. Should the CITY choose to utilize the CITY’s Builder’s Risk Program, the CITY shall be responsible for the Named Windstorm Deductible and the CONTRACTOR shall be responsible for the All Other Perils Deductible.

If and when 100% is not available or reasonable, the CITY Risk Manager is to make the determination as to what limits are appropriate for the given project.

Yes No

10.6.13 Other Insurance

10.7 REQUIRED ENDORSEMENTS

- 10.7.1 The City of Pembroke Pines shall be named as an Additional Insured on each of the Liability Policies required herein.
- 10.7.2 Waiver of all Rights of Subrogation against the CITY.
- 10.7.3 Thirty (30) calendar day Notice of Cancellation or Non-Renewal to the CITY.
- 10.7.4 CONTRACTOR’s policies shall be Primary & Non-Contributory.
- 10.7.5 All policies shall contain a “severability of interest” or “cross liability” clause without obligation for premium payment of the CITY.
- 10.7.6 The City of Pembroke Pines shall be named as a Loss Payee on all Property and/or Inland Marine Policies as their interest may appear.

10.8 Any and all insurance required of the CONTRACTOR pursuant to this Agreement must also be required by any subcontractor in the same limits and with all requirements as provided herein, including naming the CITY as an additional insured, in any work that is subcontracted unless such subcontractor is covered by the protection afforded by the CONTRACTOR and provided proof of such coverage is provided to CITY. The CONTRACTOR and any subcontractors shall maintain such policies during the term of this Agreement.

10.9 The CITY reserves the right to require any other additional types of insurance coverage and/or higher limits of liability it deems necessary based on the nature of work being performed under this Agreement.



10.10 The insurance requirements specified in this Agreement are minimum requirements and in no way reduce any liability the CONTRACTOR has assumed in the indemnification/hold harmless section(s) of this Agreement.

ARTICLE 11
NON-DISCRIMINATION & EQUAL OPPORTUNITY EMPLOYMENT

During the performance of the Agreement, neither the CONTRACTOR nor any subcontractors shall discriminate against any employee or applicant for employment because of race, religion, color, gender, national origin, sex, age, marital status, political affiliation, familial status, sexual orientation, or disability if qualified. CONTRACTOR will take affirmative action to ensure that employees are treated during employment, without regard to their race, religion, color, gender, national origin, sex, age, marital status, political affiliation, familial status, sexual orientation, or disability if qualified. Such actions must include, but not be limited to, the following: employment, promotion, demotion or transfer, recruitment or recruitment advertising, layoff or termination, rates of pay or other forms of compensation, and selection for training, including apprenticeship. CONTRACTOR shall agree to post in conspicuous places, available to employees and applicants for employment, notices to be provided by the contracting officer setting forth the provisions of this nondiscrimination clause. CONTRACTOR further agrees that CONTRACTOR will ensure that subcontractors, if any, will be made aware of and will comply with this nondiscrimination clause.

ARTICLE 12
INDEPENDENT CONTRACTOR

This Agreement does not create an employee/employer relationship between the Parties. It is the intent of the Parties that the CONTRACTOR is an independent contractor under this Agreement and not the CITY's employee for all purposes, including but not limited to, the application of the Fair Labor Standards Act minimum wage and overtime payments, Federal Insurance Contribution Act, the Social Security Act, the Federal Unemployment Tax Act, the provisions of the Internal Revenue Code, the State Workers' Compensation Act, and the State unemployment insurance law. The CONTRACTOR shall retain sole and absolute discretion in the judgment of the manner and means of carrying out CONTRACTOR's activities and responsibilities hereunder provided, further that administrative procedures applicable to services rendered under this Agreement shall be those of CONTRACTOR, which policies of CONTRACTOR shall not conflict with CITY, State, Federal, or United States policies, rules or regulations relating to the use of CONTRACTOR's funds provided for herein. The CONTRACTOR agrees that it is a separate and independent enterprise from the CITY, that it has full opportunity to find other business, that it has made its own investment in its business, and that it will utilize a high level of skill necessary to perform the work. This Agreement shall not be construed as creating any joint employment relationship between the CONTRACTOR and the CITY and the CITY will not be liable for any obligation incurred by CONTRACTOR, including but not limited to unpaid minimum wages and/or overtime premiums.

ARTICLE 13
RESERVED



ARTICLE 14
AGREEMENT SUBJECT TO FUNDING

This Agreement shall remain in full force and effect only as long as the expenditures provided for in the Agreement have been appropriated by the City Commission of the City of Pembroke Pines in the annual budget for each fiscal year of this Agreement, and is subject to termination based on lack of funding.

ARTICLE 15
UNCONTROLLABLE FORCES

15.1 Neither CITY nor CONTRACTOR shall be considered to be in default of this Agreement if delays in or failure of performance shall be due to Uncontrollable Forces, the effect of which, by the exercise of reasonable diligence, the non-performing party could not avoid. The term "Uncontrollable Forces" shall mean any event which results in the prevention or delay of performance by a party of its obligations under this Agreement and which is beyond the reasonable control of the nonperforming party. It includes, but is not limited to fire, flood, earthquakes, storms, lightning, epidemic, pandemic, acts of God, war, riot, civil disturbance, sabotage, and governmental actions.

15.2 Neither party shall, however, be excused from performance if nonperformance is due to forces, which are preventable, removable, or remediable, and which the nonperforming party could have, with the exercise of reasonable diligence, prevented, removed, or remedied with reasonable dispatch. The nonperforming party shall, within a reasonable time of being prevented or delayed from performance by an uncontrollable force, give written notice to the other party describing the circumstances and uncontrollable forces preventing continued performance of the obligations of this Agreement.

ARTICLE 16
GOVERNING LAW AND VENUE

This Agreement shall be governed by and construed in accordance with the laws of the State of Florida as now and hereafter in force. The venue for any and all actions or claims arising out of or related to this Agreement shall be in Broward County, Florida.

ARTICLE 17
SIGNATORY AUTHORITY

Upon CITY's request, CONTRACTOR shall provide CITY with copies of requisite documentation evidencing that the signatory for CONTRACTOR has the authority to enter into this Agreement.

ARTICLE 18
DEFAULT OF CONTRACT & REMEDIES

18.1 **Damages.** CITY reserves the right to recover any ascertainable actual damages incurred as a result of the failure of CONTRACTOR to perform in accordance with the requirements of this



Agreement, or for losses sustained by CITY resultant from CONTRACTOR's failure to perform in accordance with the requirements of this Agreement.

18.2 **Liquidated Damages.** As a breach of the service provided by this Agreement would cause serious and substantial damage to CITY Property, and the nature of this Agreement would render it impracticable or extremely difficult to fix the actual damage sustained by CITY by such breach, it is agreed that, in case of breach of service wherein CONTRACTOR fails to maintain the Property, leaving the said property in disrepair, CITY may elect to collect liquidated damages for each such breach, and CONTRACTOR will pay CITY as liquidated damages, and not as penalty, {---**Liquidated Damages Amount Written---**} (\$**{---Liquidated Damages Amount---**}) for every day of such malfunction. This sum is the agreed upon amount by which CITY will be damaged by the breach of such service. An election to seek such remedies shall not be construed as a waiver of any legal remedies CITY may have as to any subsequent breach of service under this Agreement.

18.3 **Correction of Work.** If, in the judgment of CITY, work provided by CONTRACTOR does not conform to the requirements of this Agreement, or if the work exhibits poor workmanship, CITY reserves the right to require that CONTRACTOR correct all deficiencies in the work to bring the work into conformance without additional cost to CITY, and/or replace any personnel who fail to perform in accordance with the requirements of this Agreement. CITY shall be the sole judge of non-conformance and the quality of workmanship.

18.4 **Default of Contract.** The occurrence of any one or more of the following events shall constitute a default and breach of this Agreement by CONTRACTOR:

18.4.1 The abandonment of the Property by CONTRACTOR for a period of more than seven (7) business days.

18.4.2 The abandonment, unnecessary delay, refusal of, or failure to comply with any of the terms of this Agreement or neglect, or refusal to comply with the instructions of the CITY's Authorized Representative relative thereto.

18.4.3 The failure by CONTRACTOR to observe or perform any of the terms, covenants, or conditions of this Agreement to be observed or performed by CONTRACTOR, where such failure shall continue for a period of seven (7) calendar days after written notice thereof by CITY to CONTRACTOR; provided, however, that if the nature of CONTRACTOR's default is such that more than seven (7) calendar days are reasonably required for its cure, then CONTRACTOR shall not be deemed to be in default if CONTRACTOR commences such cure within said seven (7) calendar day period and thereafter diligently prosecutes such cure to completion.

18.4.4 The assignment and/or transfer of this Agreement or execution or attachment thereon by CONTRACTOR or any other party in a manner not expressly permitted hereunder.

18.4.5 The making by CONTRACTOR of any general assignment or general arrangement for the benefit of creditors, or the filing by or against CONTRACTOR of a petition to have



CONTRACTOR adjudged a bankruptcy, or a petition for reorganization or arrangement under any law relating to bankruptcy (unless, in the case of a petition filed against CONTRACTOR, the same is dismissed within sixty (60) calendar days); or the appointment of a trustee or a receiver to take possession of substantially all of CONTRACTOR's assets, or for CONTRACTOR's interest in this Agreement, where possession is not restored to CONTRACTOR within thirty (30) calendar days; for attachment, execution or other judicial seizure of substantially all of CONTRACTOR's assets, or for CONTRACTOR's interest in this Agreement, where such seizure is not discharged within thirty (30) calendar days.

18.5 **Remedies in Default.** In case of default by CONTRACTOR, CITY shall notify CONTRACTOR, in writing, of such abandonment, delay, refusal, failure, neglect, or default and direct CONTRACTOR to comply with all provisions of this Agreement. A copy of such written notice shall be mailed to the Surety on the Performance Bond. If the abandonment, delay, refusal, failure, neglect or default is not cured within seven (7) calendar days of when notice was sent by CITY, CITY may declare a default of the Agreement and notify CONTRACTOR of such declaration of default and terminate the Agreement. The Surety on the Performance Bond shall within ten (10) days of such declaration of default, rectify or cause to be rectified any mismanagement or breach of service in the Agreement and assume the work of CONTRACTOR and proceed to perform services under the Agreement, at its own cost and expense.

18.5.1 Upon such declaration of default, all payments remaining due CONTRACTOR at the time of default, less all sums due CITY for damages suffered, or expenses incurred by reason of default, shall be due and payable to Surety. Thereafter the Surety shall receive monthly payments equal to those that would have been paid by the CONTRACTOR had the CONTRACTOR continued to perform the services under the Agreement.

18.5.2 CITY may complete the Agreement, or any part thereof, either by day labor or re-letting a contract for the same, and procure the equipment and the facilities necessary for the completion of the Agreement, and charge the cost of same to CONTRACTOR and/or the Surety together with the costs incident thereto to such default. CITY reserves the right to assign any remaining work at any Property location to another vendor as may be necessary to complete the Scope of Work.

18.5.3 In the event CITY completes the Agreement at a lesser cost than would have been payable to CONTRACTOR under this Agreement, if the same had been fulfilled by CONTRACTOR, CITY shall retain such differences. Should such cost to CITY be greater, CONTRACTOR shall pay the amount of such excess to the CITY.

18.5.4 Notwithstanding the other provisions in this Article, CITY reserves the right to terminate the Agreement at any time, whenever the service provided by CONTRACTOR fails to meet reasonable standards of the trade after CITY gives written notice to the CONTRACTOR of the deficiencies as set forth in the written notice within fourteen (14) calendar days of the receipt by CONTRACTOR of such notice from CITY.

ARTICLE 19



BANKRUPTCY

It is agreed that if CONTRACTOR is adjudged bankrupt, either voluntarily or involuntarily, then this Agreement shall terminate effective on the date and at the time the bankruptcy petition is filed.

ARTICLE 20 **MERGER; AMENDMENT**

This Agreement constitutes the entire Agreement between CONTRACTOR and CITY, and all negotiations and oral understandings between the Parties are merged herein. This Agreement can be supplemented or amended only by a written document executed by both CONTRACTOR and CITY with the same formality and equal dignity herewith.

ARTICLE 21 **DISPUTE RESOLUTION**

In the event that a dispute, if any, arises between CITY and CONTRACTOR relating to this Agreement, performance or compensation hereunder, CONTRACTOR shall continue to render service in full compliance with all terms and conditions of this Agreement as interpreted by CITY regardless of such dispute. CONTRACTOR expressly recognizes the paramount right and duty of CITY to provide adequate maintenance of CITY's Property, and further agrees, in consideration for the execution of this Agreement, that in the event of such a dispute, if any, it will not seek injunctive relief in any court, but will negotiate with CITY for an adjustment on the matter or matters in dispute and, upon failure of said negotiations to resolve the dispute, may present the matter to a court of competent jurisdiction in an appropriate suit therefore instituted by it or by CITY.

ARTICLE 22 **PUBLIC RECORDS**

22.1 The City of Pembroke Pines is public agency subject to Chapter 119, Florida Statutes. The CONTRACTOR shall comply with Florida's Public Records Law. Specifically, the CONTRACTOR shall:

22.1.1 Keep and maintain public records required by the CITY to perform the service;

22.1.2 Upon request from the CITY's custodian of public records, provide the CITY with a copy of the requested records or allow the records to be inspected or copied within a reasonable time at a cost that does not exceed the cost provided in Chapter 119, Florida Statutes, or as otherwise provided by law;

22.1.3 Ensure that public records that are exempt or that are confidential and exempt from public record disclosure requirements are not disclosed except as authorized by law for the duration of the Agreement term and, following completion of the Agreement, CONTRACTOR shall destroy all copies of such confidential and exempt records remaining



in its possession after the CONTRACTOR transfers the records in its possession to the CITY; and

22.1.4 Upon completion of the Agreement, CONTRACTOR shall transfer to the CITY, at no cost to the CITY, all public records in CONTRACTOR's possession. All records stored electronically by the CONTRACTOR must be provided to the CITY, upon request from the CITY's custodian of public records, in a format that is compatible with the information technology systems of the CITY.

22.2 The failure of CONTRACTOR to comply with the provisions set forth in this Article shall constitute a Default and Breach of this Agreement and the CITY shall enforce the Default in accordance with this Agreement.

IF CONTRACTOR HAS QUESTIONS REGARDING THE APPLICATION OF CHAPTER 119, FLORIDA STATUTES, TO CONTRACTOR'S DUTY TO PROVIDE PUBLIC RECORDS RELATING TO THIS AGREEMENT, CONTACT THE CUSTODIAN OF PUBLIC RECORDS AT:

**CITY CLERK
601 CITY CENTER WAY, 4th FLOOR
PEMBROKE PINES, FL 33025
(954) 450-1050
drogers@ppines.com**

ARTICLE 23
SCRUTINIZED COMPANIES

23.1 CONTRACTOR, its principals or owners, certify that they are not listed on the Scrutinized Companies that Boycott Israel List, Scrutinized Companies with Activities in Sudan List, Scrutinized Companies with Activities in Iran Terrorism Sectors List, or is engaged in business operations with Syria. In accordance with Section 287.135, Florida Statutes, as amended, a company is ineligible to, and may not, bid on, submit a proposal for, or enter into or renew a contract with any agency or local governmental entity for goods or services of:

23.1.1 Any amount if, at the time bidding on, submitting a proposal for, or entering into or renewing such contract, the company is on the Scrutinized Companies that Boycott Israel List, created pursuant to Section 215.4725, Florida Statutes, or is engaged in a boycott of Israel; or

23.1.2 One million dollars or more if, at the time of bidding on, submitting a proposal for, or entering into or renewing such contract, the company:



23.1.2.1 Is on the Scrutinized Companies with Activities in Sudan List or the Scrutinized Companies with Activities in Iran Terrorism Sectors List, created pursuant to Section 215.473, Florida Statutes; or

23.1.2.2 Is engaged in business operations in Syria.

ARTICLE 24

EQUAL BENEFITS FOR EMPLOYEES

24.1 CONTRACTOR certifies that it is aware of the requirements of Section 35.39 of the CITY's Code of Ordinances and certifies that it is aware of the requirements of Section 35.39 of the CITY's Code of Ordinances and certifies that (**check only one box below**):

- CONTRACTOR currently complies with the requirements of Section 35.39 of the CITY's Code of Ordinances; or
- CONTRACTOR will comply with the conditions of Section 35.39 of the CITY's Code of Ordinances; or
- CONTRACTOR will not comply with the conditions of Section 35.39 of the CITY's Code of Ordinances; or
- CONTRACTOR does not comply with the conditions of Section 35.39 of the CITY's Code of Ordinances because of the following allowable exemption (**check only box below**):
 - CONTRACTOR does not provide benefits to employees' spouses in traditional marriages; or
 - CONTRACTOR provides an employee the cash equivalent of benefits because CONTRACTOR is unable to provide benefits to employees' Domestic Partners or spouses despite making reasonable efforts to provide them. To meet this exception, CONTRACTOR shall provide a notarized affidavit that it has made reasonable efforts to provide such benefits. The affidavit shall state the efforts taken to provide such benefits and the amount of the cash equivalent. Case equivalent means the amount of money paid to an employee with a Domestic Partner or spouse rather than providing benefits to the employee's Domestic Partner or spouse. The case equivalent is equal to the employer's direct expense of providing benefits to an employee's spouse; or
 - CONTRACTOR is a religious organization, association, society, or any non-profit charitable or educational institution or organization operated, supervised, or controlled by or in conjunction with a religious organization, association, or society; or
 - CONTRACTOR is a governmental agency.

24.2 Except where federal or state law mandates to the contrary, a contractor awarded a contract pursuant to a competitive solicitation shall provide benefits to Domestic Partners and spouses of



its employees, irrespective of gender, on the same basis as it provides benefits to employees' spouses in traditional marriages.

24.3 CONTRACTOR shall provide the City Manager and his/her designee, access to its records for the purpose of audits and/or investigations to ascertain compliance with the provisions of this Article, and upon request shall provide evidence that the CONTRACTOR is in compliance with the provisions of this Article upon the renewal of this AGREEMENT or when the City Manager or his/her designee receives a complaint or has reason to believe CONTRACTOR may not be in compliance with the provisions of this Article. Records shall include but not be limited to providing the City Manager and his/her designee with certified copies of CONTRACTOR's records pertaining to its benefits policies and its employment policies and practices.

24.4 CONTRACTOR must conspicuously make available to all employees and applicants for employment the following statement:

“During the performance of a contract with the City of Pembroke Pines, Florida, the CONTRACTOR will provide Equal Benefits to its employees with spouses, as defined by Section 35.39 of the City of Pembroke Pines Code of Ordinances, and its employees with Domestic Partners and all Married Couples”.

If CONTRACTOR has questions regarding the application of Section 35.39 of the City of Pembroke Pines Code of Ordinances to CONTRACTOR's duties pursuant to this Agreement, contact Human Resources at (954) 392-2092 or drotstein@ppines.com.

24.5 By executing this Agreement, CONTRACTOR certifies that it agrees to comply with the above and Section 35.39 of the City of Pembroke Pines Code of Ordinances, as may be amended from time to time.

ARTICLE 25

EMPLOYMENT ELIGIBILITY

25.1 **E-Verify.** CONTRACTOR certifies that it is aware of and complies with the requirements of Section 448.095, Florida Statutes, as may be amended from time to time and briefly described herein below.

25.1.1 Definitions for this Section.

25.1.1.1 “Contractor” means a person or entity that has entered or is attempting to enter into a contract with a public employer to provide labor, supplies, or services to such employer in exchange for salary, wages, or other remuneration.

25.1.1.2 “Contractor” includes, but is not limited to, a vendor or consultant.

25.1.1.3 “Subcontractor” means a person or entity that provides labor,



supplies, or services to or for a contractor or another subcontractor in exchange for salary, wages, or other remuneration.

25.1.1.4 "E-Verify system" means an Internet-based system operated by the United States Department of Homeland Security that allows participating employers to electronically verify the employment eligibility of newly hired employees.

25.2 **Registration Requirement; Termination.** Pursuant to Section 448.095, Florida Statutes, effective January 1, 2021, Contractors, shall register with and use the E-verify system in order to verify the work authorization status of all newly hired employees. Contractor shall register for and utilize the U.S. Department of Homeland Security's E-Verify System to verify the employment eligibility of:

25.2.1 All persons employed by a Contractor to perform employment duties within Florida during the term of the contract; and

25.2.2 All persons (including subvendors/subconsultants/subcontractors) assigned by Contractor to perform work pursuant to the contract with the City of Pembroke Pines. The Contractor acknowledges and agrees that registration and use of the U.S. Department of Homeland Security's E-Verify System during the term of the contract is a condition of the contract with the City of Pembroke Pines; and

25.2.3 The Contractor shall comply with the provisions of Section 448.095, Fla. Stat., "Employment Eligibility," as amended from time to time. This includes, but is not limited to registration and utilization of the E-Verify System to verify the work authorization status of all newly hired employees. Contractor shall also require all subcontractors to provide an affidavit attesting that the subcontractor does not employ, contract with, or subcontract with, an unauthorized alien. The Contractor shall maintain a copy of such affidavit for the duration of the contract. Failure to comply will lead to termination of this Contract, or if a subcontractor knowingly violates the statute, the subcontract must be terminated immediately. Any challenge to termination under this provision must be filed in the Circuit Court no later than twenty (20) calendar days after the date of termination. Termination of this Contract under this Section is not a breach of contract and may not be considered as such. If this contract is terminated for a violation of the statute by the Contractor, the Contractor may not be awarded a public contract for a period of one (1) year after the date of termination.

ARTICLE 26

FEDERAL REQUIREMENTS

Notwithstanding anything to the contrary set forth herein, CONTRACTOR shall comply with the applicable federal requirements set forth in 2 C.F.R. Part 200, as may be applicable. In the event of any conflicts, the provisions of 2 C.F.R. Part 200 shall prevail. Any reference made to CONTRACTOR in this section shall also apply to any subcontractor under the terms of this Agreement. The prime contractor shall be responsible for the compliance by any subcontractor or lower tier subcontractor with all of these contract clauses:



26.1 **Equal Employment Opportunity**. During the performance of this contract, CONTRACTOR agrees as follows:

26.1.1 CONTRACTOR will not discriminate against any employee or applicant for employment because of race, color, religion, sex, sexual orientation, gender identity, or national origin. CONTRACTOR will take affirmative action to ensure that applicants are employed, and that employees are treated during employment, without regard to their race, color, religion, sex, sexual orientation, gender identity, or national origin. Such action shall include, but not be limited to the following: Employment, upgrading, demotion, or transfer, recruitment or recruitment advertising; layoff or termination; rates of pay or other forms of compensation; and selection for training, including apprenticeship. CONTRACTOR agrees to post in conspicuous places, available to employees and applicants for employment, notices to be provided by the contracting officer setting forth the provisions of this nondiscrimination clause.

26.1.2 CONTRACTOR will, in all solicitations or advertisements for employees placed by or on behalf of CONTRACTOR, state that all qualified applicants will receive consideration for employment without regard to race, color, religion, sex, sexual orientation, gender identity, or national origin.

26.1.3 CONTRACTOR will not discharge or in any other manner discriminate against any employee or applicant for employment because such employee or applicant has inquired about, discussed, or disclosed the compensation of the employee or applicant or another employee or applicant. This provision shall not apply to instances in which an employee who has access to the compensation information of other employees or applicants as a part of such employee's essential job functions discloses the compensation of such other employees or applicants to individuals who do not otherwise have access to such information, unless such disclosure is in response to a formal complaint or charge, in furtherance of an investigation, proceeding, hearing, or action, including an investigation conducted by the employer, or is consistent with CONTRACTOR's legal duty to furnish information.

26.1.4 CONTRACTOR will send to each labor union or representative of workers with which it has a collective bargaining agreement or other contract or understanding, a notice to be provided by the agency contracting officer, advising the labor union or workers' representative of CONTRACTOR's commitments under section 202 of Executive Order 11246 of September 24, 1965, and shall post copies of the notice in conspicuous places available to employees and applicants for employment.

26.1.5 CONTRACTOR will comply with all provisions of Executive Order 11246 of September 24, 1965, and of the rules, regulations, and relevant orders of the Secretary of Labor.

26.1.6 CONTRACTOR will furnish all information and reports required by Executive Order 11246 of September 24, 1965, and by the rules, regulations, and orders of the Secretary



of Labor, or pursuant thereto, and will permit access to his books, records, and accounts by the contracting agency and the Secretary of Labor for purposes of investigation to ascertain compliance with such rules, regulations, and orders.

26.1.7 In the event of CONTRACTOR's non-compliance with the nondiscrimination clauses of this contract or with any of such rules, regulations, or orders, this Agreement may be canceled, terminated or suspended in whole or in part and CONTRACTOR may be declared ineligible for further Government contracts in accordance with procedures authorized in Executive Order 11246 of September 24, 1965, and such other sanctions may be imposed and remedies invoked as provided in Executive Order 11246 of September 24, 1965, or by rule, regulation, or order of the Secretary of Labor, or as otherwise provided by law.

26.1.8 CONTRACTOR will include the provisions of paragraphs **(26.1.1)** through **(26.1.8)** in every subcontract or purchase order unless exempted by rules, regulations, or orders of the Secretary of Labor issued pursuant to section 204 of Executive Order 11246 of September 24, 1965, so that such provisions will be binding upon each subcontractor or vendor. CONTRACTOR will take such action with respect to any subcontract or purchase order as may be directed by the Secretary of Labor as a means of enforcing such provisions including sanctions for noncompliance: *Provided*, however, that in the event CONTRACTOR becomes involved in, or is threatened with, litigation with a subcontractor or vendor as a result of such direction, CONTRACTOR may request the United States to enter into such litigation to protect the interests of the United States.

The CITY further agrees that it will be bound by the above equal opportunity clause with respect to its own employment practices when it participates in federally assisted construction work: *Provided*, that if the CITY so participating is a state or local government, the above equal opportunity clause is not applicable to any agency, instrumentality or subdivision of such government which does not participate in work on or under the contract.

The CITY further agrees that it will assist and cooperate actively with the administering agency and the Secretary of Labor in obtaining the compliance of contractors and subcontractors with the equal opportunity clause and the rules, regulations, and relevant orders of the Secretary of Labor, that it will furnish the administering agency and the Secretary of Labor such information as they may require for the supervision of such compliance, and that it will otherwise assist the administering agency in the discharge of the agency's primary responsibility for securing compliance.

The CITY further agrees that it will refrain from entering into any contract or contract modification subject to Executive Order 11246 of September 24, 1965, with a contractor debarred from, or who has not demonstrated eligibility for, Government contracts and federally assisted construction contracts pursuant to the Executive Order and will carry out such sanctions and penalties for violation of the equal opportunity clause as may be imposed upon contractors and subcontractors by the administering agency or the Secretary of Labor pursuant to Part II, Subpart D of the Executive Order. In addition, the CITY agrees that if it fails or refuses to comply with these undertakings, the administering agency may take any or



all of the following actions: Cancel, terminate, or suspend in whole or in part this grant (contract, loan, insurance, guarantee); refrain from extending any further assistance to the CITY under the program with respect to which the failure or refund occurred until satisfactory assurance of future compliance has been received from such CITY; and refer the case to the Department of Justice for appropriate legal proceedings.

26.2 **Davis-Bacon Act.** CONTRACTOR shall comply with the Davis-Bacon Act (40 U.S.C. 276a to 276a-7) as supplemented by Department of Labor Regulations (29 CFR Part 5). In accordance with the statute, CONTRACTOR must be required to pay wages to laborers and mechanics at a rate not less than the prevailing wages specified in a wage determination made by the Secretary of Labor. In addition, CONTRACTOR must be required to pay wages not less than once a week.

26.3 **Copeland “Anti-Kickback” Act.** CONTRACTOR shall comply with the Copeland “Anti-Kickback” Act, (40 U.S.C. 3145), as supplemented by Department of Labor regulations (29 CFR Part 3, “Contractors and Subcontractors on Public Building or Public Work Financed in Whole or in Part by Loans or Grants from the United States”). CONTRACTOR must be prohibited from inducing, by any means, any person employed in the construction, completion, or repair of public work, to give up any part of the compensation to which he or she is otherwise entitled. CITY must report all suspected or reported violations to the Federal awarding agency.

26.4 **Contract Work Hours and Safety Standards Act (40 U.S.C. 3701- 3708).** Where applicable, pursuant to 40 U.S.C. 3702 and 3704, as supplemented by Department of Labor regulations (29 CFR Part 5) CONTRACTOR must be required to compute the wages of every mechanic and laborer on the basis of a standard work week of 40 hours. Work in excess of the standard work week is permissible provided that the worker is compensated at a rate of not less than one and a half times the basic rate of pay for all hours worked in excess of 40 hours in the work week. The requirements of 40 U.S.C. 3704 are applicable to construction work and provide that no laborer or mechanic must be required to work in surroundings or under working conditions which are unsanitary, hazardous or dangerous.

26.4.1 **Overtime requirements.** No contractor or subcontractor contracting for any part of the contract work which may require or involve the employment of laborers or mechanics shall require or permit any such laborer or mechanic in any workweek in which he or she is employed on such work to work in excess of forty hours in such workweek unless such laborer or mechanic receives compensation at a rate not less than one and one-half times the basic rate of pay for all hours worked in excess of forty hours in such workweek.

26.4.2 **Violation; liability for unpaid wages; liquidated damages.** In the event of any violation of the clause set forth in paragraph (25.4.1) of this section the CONTRACTOR and any subcontractor responsible therefor shall be liable for the unpaid wages. In addition, such contractor and subcontractor shall be liable to the United States (in the case of work done under contract for the District of Columbia or a territory, to such District or to such territory), for liquidated damages. Such liquidated damages shall be computed with respect to each individual laborer or mechanic, including watchmen and guards, employed in



violation of the clause set forth in paragraph (25.4.1) of this section, in the sum of \$10 for each calendar day on which such individual was required or permitted to work in excess of the standard workweek of forty hours without payment of the overtime wages required by the clause set forth in paragraph (25.4.1) of this section.

26.4.3 **Withholding for unpaid wages and liquidated damages.** CITY shall upon its own action or upon written request of an authorized representative of the Department of Labor withhold or cause to be withheld, from any moneys payable on account of work performed by CONTRACTOR or subcontractor under any such contract or any other Federal contract with the same prime contractor, or any other federally-assisted contract subject to the Contract Work Hours and Safety Standards Act, which is held by the same prime contractor, such sums as may be determined to be necessary to satisfy any liabilities of such contractor or subcontractor for unpaid wages and liquidated damages as provided in the clause set forth in paragraph (25.4.2) of this section.

26.4.4 **Subcontracts.** CONTRACTOR or subcontractor shall insert in any subcontracts the clauses set forth in paragraph (25.4.1) through (25.4.4) of this section and also a clause requiring the subcontractors to include these clauses in any lower tier subcontracts. The prime contractor shall be responsible for compliance by any subcontractor or lower tier subcontractor with the clauses set forth in paragraphs (25.4.1) through (25.4.4) of this section.

26.5 CONTRACTOR agrees to comply with all applicable standards, orders or regulations issued pursuant to the Clean Air Act (42 U.S.C. 7401- 7671q) and the Federal Water Pollution Control Act, as amended (33 U.S.C. 1251- 1387). CITY will report violations to the Federal awarding agency and the Regional Office of the Environmental Protection Agency (EPA).

26.5.1 **Clean Air Act.** CONTRACTOR agrees to comply with all applicable standards, orders or regulations issued pursuant to the Clean Air Act, as amended, 42 U.S.C. § 7401 et seq. CONTRACTOR agrees to report each violation to CITY and understands and agrees that the CITY will, in turn, report each violation as required to assure notification to the State, Federal Emergency Management Agency, and the appropriate Environmental Protection Agency Regional Office. CONTRACTOR agrees to include these requirements in each subcontract exceeding \$150,000 financed in whole or in part with Federal assistance.

26.5.2 **Federal Water Pollution Control Act.** CONTRACTOR agrees to comply with all applicable standards, orders or regulations issued pursuant to the Federal Water Pollution Control Act, as amended, 33 U.S.C. 1251 et seq. CONTRACTOR agrees to report each violation to the CITY and understands and agrees that the CITY will, in turn, report each violation as required to assure notification to the State, Federal Emergency Management Agency, and the appropriate Environmental Protection Agency Regional Office. CONTRACTOR agrees to include these requirements in each subcontract exceeding one hundred fifty thousand dollars (\$150,000) financed in whole or in part with Federal assistance.



26.6 **Suspension and Debarment.** This Agreement is a covered transaction for purposes of 2 C.F.R. pt. 180 and 2 C.F.R. pt. 3000, as such CONTRACTOR is required to verify that none of the contractor's agents, principals (defined at 2 C.F.R. § 180.995), or affiliates (defined at 2 C.F.R. § 180.905) are excluded (defined at 2 C.F.R. § 180.940) or disqualified (defined at 2 C.F.R. § 180.935).

26.6.1 CONTRACTOR must comply with 2 C.F.R. pt. 180, subpart C and 2 C.F.R. pt. 3000, subpart C and must include a requirement to comply with these regulations in any lower tier covered transaction it enters into. This certification is a material representation of fact relied upon by CITY. If it is later determined that CONTRACTOR did not comply with 2 C.F.R. pt. 180, subpart C and 2 C.F.R. pt. 3000, subpart C, in addition to remedies available to State and CITY, the Federal Government may pursue available remedies, including but not limited to suspension and/or debarment.

26.6.2 The bidder or proposer agrees to comply with the requirements of 2 C.F.R. pt. 180, subpart C and 2 C.F.R. pt. 3000, subpart C while this offer is valid and throughout the period of any contract that may arise from this offer. The bidder or proposer further agrees to include a provision requiring such compliance in its lower tier covered transactions.

26.7 **Byrd Anti-Lobbying Amendment, as amended (31 U.S.C. § 1352).** CONTRACTOR shall file the required certification pursuant to 31 U.S.C. 1352. Each tier certifies to the tier above that it will not and has not used Federal appropriated funds to pay any person or organization for influencing or attempting to influence an officer or employee of any agency, a member of Congress, officer or employee of Congress, or an employee of a member of Congress in connection with obtaining any Federal contract, grant, or any other award covered by 31 U.S.C. § 1352. Each tier shall also disclose any lobbying with non-Federal funds that takes place in connection with obtaining any Federal award. Such disclosures are forwarded from tier to tier up to the recipient.

26.8 **Compliance with State Energy Policy and Conservation Act.** CONTRACTOR shall comply with all mandatory standards and policies relating to energy efficiency contained in the State energy conservation plan issued in compliance with the Energy Policy and Conservation Act (Pub. L. 94-163, 89 Stat. 871).

26.9 **Procurement of Recovered Materials.** The CITY and CONTRACTOR must comply with Section 6002 of the Solid Waste Disposal Act, as amended by the Resource Conservation and Recovery Act. The requirements of Section 6002 include procuring only items designated in guidelines of the Environmental Protection Agency (EPA) at 40 CFR part 247 that contain the highest percentage of recovered materials practicable, consistent with maintaining a satisfactory level of competition, where the purchase price of the item exceeds \$10,000 or the value of the quantity acquired during the preceding fiscal year exceeded \$10,000; procuring solid waste management services in a manner that maximizes energy and resource recovery; and establishing an affirmative procurement program for procurement of recovered materials identified in the EPA guidelines.

26.10 **Reporting.** Pursuant to 44 CFR 13.36(i)(7), CONTRACTOR shall comply with federal requirements and regulations pertaining to reporting, including but not limited to those set forth at



44 CFR 40 and 41, if applicable. Furthermore, both parties shall provide the FEMA Administrator, the Comptroller General of the United States, or any of their authorized representative access to any books, documents, papers, and records of CONTRACTOR which are directly pertinent to this contract for the purpose of making audits, examinations, excerpts, and transcriptions. Also, both Parties agree to provide FEMA Administrator or his authorized representative access to construction or other work sites pertaining to the work being completed under the Agreement.

26.11 **Rights to Inventions.** CONTRACTOR agrees that if this Agreement results in any copyrightable materials or inventions, the Federal Government reserves a royalty-free, nonexclusive and irrevocable license to reproduce, publish or otherwise use the copyright of said materials or inventions for Federal Government purposes.

26.12 **No Obligation by the Federal Government.** The federal government is not a party to this contract and is not subject to any obligations or liabilities to the non-federal entity, contractor, or any other party pertaining to any matter resulting from the contract.

26.13 **DHS Seal, Logo, and Flags.** CONTRACTOR shall not use DHS(s), logos, crests, or reproductions of flags or likenesses of DHS agency officials without specific federal pre-approval.

26.14 **Compliance with Federal Law, Regulations, and Executive Orders.** This is an acknowledgement that federal financial assistance will be used to fund the Agreement only. CONTRACTOR will comply with all applicable federal law, regulations, executive orders, policies, procedures, and directives.

26.15 **Fraudulent Statements.** CONTRACTOR acknowledges that 31 U.S.C. Chap. 38 applies to CONTRACTOR's actions pertaining to this Agreement.

26.16 **Prohibition on Contracting for Covered Telecommunications Equipment or Services.** As used in this clause, the terms backhaul; covered foreign country; covered telecommunications equipment or services; interconnection arrangements; roaming; substantial or essential component; and telecommunications equipment or services have the meaning as defined in FEMA Policy 405-143-1, Prohibitions on Expending FEMA Award Funds for Covered Telecommunications Equipment or Services (Interim), as used in this clause.

26.16.1 **Prohibitions.**

26.16.1.1 Section 889(b) of the John S. McCain National Defense Authorization Act for Fiscal Year 2019, Pub. L. No. 115-232, and 2 C.F.R. § 200.216 prohibit the head of an executive agency on or after Aug. 13, 2020, from obligating or expending grant, cooperative agreement, loan, or loan guarantee funds on certain telecommunications products or from certain entities for national security reasons.

26.16.1.2 Unless an exception in paragraph 25.16.3 of this clause applies, the CONTRACTOR and its subcontractors may not use grant, cooperative agreement, loan, or loan guarantee funds from the Federal Emergency Management Agency to:



26.16.1.2.1 Procure or obtain any equipment, system, or service that uses covered telecommunications equipment or services as a substantial or essential component of any system, or as critical technology of any system;

26.16.1.2.2 Enter into, extend, or renew a contract to procure or obtain any equipment, system, or service that uses covered telecommunications equipment or services as a substantial or essential component of any system, or as critical technology of any system;

26.16.1.2.3 Enter into, extend, or renew contracts with entities that use covered telecommunications equipment or services as a substantial or essential component of any system, or as critical technology as part of any system; or

26.16.1.2.4 Provide, as part of its performance of this contract, subcontract, or other contractual instrument, any equipment, system, or service that uses covered telecommunications equipment or services as a substantial or essential component of any system, or as critical technology as part of any system.

26.16.2 **Exceptions.**

26.16.2.1 This clause does not prohibit CONTRACTOR from providing: (i) A service that connects to the facilities of a third-party, such as backhaul, roaming, or interconnection arrangements; or (ii) Telecommunications equipment that cannot route or redirect user data traffic or permit visibility into any user data or packets that such equipment transmits or otherwise handles.

26.16.2.2 By necessary implication and regulation, the prohibitions also do not apply to: (i) Covered telecommunications equipment or services that: i. Are not used as a substantial or essential component of any system; and ii. Are not used as critical technology of any system. (ii) Other telecommunications equipment or services that are not considered covered telecommunications equipment or services.

26.16.3 **Reporting requirement.**

26.16.3.1 In the event CONTRACTOR identifies covered telecommunications equipment or services used as a substantial or essential component of any system, or as critical technology as part of any system, during contract performance, or the contractor is notified of such by a subcontractor at any tier or by any other source, the contractor shall report the information in paragraph 25.16.3.2 of this clause to the recipient or subrecipient, unless elsewhere in this contract are established procedures for reporting the information.



26.16.3.2 The CONTRACTOR shall report the following information pursuant to paragraph 25.16.3.1 of this clause: (i) Within one business day from the date of such identification or notification: The contract number; the order number(s), if applicable; supplier name; supplier unique entity identifier (if known); supplier Commercial and Government Entity (CAGE) code (if known); brand; model number (original equipment manufacturer number, manufacturer part number, or wholesaler number); item description; and any readily available information about mitigation actions undertaken or recommended. (ii) Within ten (10) business days of submitting the information in paragraph 25.16.3.1 of this clause: Any further available information about mitigation actions undertaken or recommended. In addition, the contractor shall describe the efforts it undertook to prevent use or submission of covered telecommunications equipment or services, and any additional efforts that will be incorporated to prevent future use or submission of covered telecommunications equipment or services. The CONTRACTOR shall insert the substance of this clause, including this in all subcontracts and other contractual instruments.

26.17 **Domestic Preference for Procurements.** As appropriate, and to the extent consistent with law, the CONTRACTOR should, to the greatest extent practicable, provide a preference for the purchase, acquisition, or use of goods, products, or materials produced in the United States. This includes, but is not limited to iron, aluminum, steel, cement, and other manufactured products. For purposes of this clause: *Produced in the United States* means, for iron and steel products, that all manufacturing processes, from the initial melting stage through the application of coatings, occurred in the United States. *Manufactured products* mean items and construction materials composed in whole or in part of non-ferrous metals such as aluminum; plastics and polymer-based products such as polyvinyl chloride pipe; aggregates such as concrete; glass, including optical fiber; and lumber.

26.18 **Affirmative Socioeconomic Steps.** If subcontracts are to be let, CONTRACTOR is required to take all necessary steps identified in 2 C.F.R. § 200.321(b)(1)-(5) to ensure that small and minority businesses, women's business enterprises, and labor surplus area firms are used when possible.

26.19 **License and Delivery of Works Subject to Copyright and Data Rights.** If applicable, the CONTRACTOR grants to CITY, a paid-up, royalty-free, nonexclusive, irrevocable, worldwide license in data first produced in the performance of this contract to reproduce, publish, or otherwise use, including prepare derivative works, distribute copies to the public, and perform publicly and display publicly such data. For data required by the contract but not first produced in the performance of this contract, CONTRACTOR will identify such data and grant to the CITY or acquires on its behalf a license of the same scope as for data first produced in the performance of this contract. Data, as used herein, shall include any work subject to copyright under 17 U.S.C. § 102, for example, any written reports or literary works, software and/or source code, music, choreography, pictures or images, graphics, sculptures, videos, motion pictures or other audiovisual works, sound and/or video recordings, and architectural works. Upon or before the completion of this contract, CONTRACTOR will deliver to the CONTRACTOR data first



produced in the performance of this contract and data required by the contract but not first produced in the performance of this contract in formats acceptable by CONTRACTOR.

ARTICLE 27 **MISCELLANEOUS**

27.1 **Ownership of Documents.** Reports, surveys, studies, and other data provided in connection with this Agreement are and shall remain the property of CITY, whether or not the project for which they are made is completed.

27.2 **Legal Representation.** It is acknowledged that each party to this Agreement had the opportunity to be represented by counsel in the preparation of this Agreement, and accordingly, the rule that a contract shall be interpreted strictly against the party preparing same shall not apply herein due to the joint contributions of both Parties.

27.3 **Records.** CONTRACTOR shall keep such records and accounts and require any and all subcontractors to keep records and accounts as may be necessary in order to record complete and correct entries as to personnel hours charged to this engagement, and any expenses for which CONTRACTOR expects to be reimbursed. Such books and records will be available at all reasonable times for examination and audit by CITY and shall be kept for a period of ten (10) years after the completion of all work to be performed pursuant to this Agreement. Incomplete or incorrect entries in such books and records will be grounds for disallowance by CITY of any fees or expenses based upon such entries. All records shall be maintained and available for disclosure, as appropriate, in accordance with Chapter 119, Florida Statutes.

27.4 **Assignments; Amendments.** This Agreement, and any interests herein, shall not be assigned, transferred or otherwise encumbered, under any circumstances, by CONTRACTOR without the prior written consent of CITY. For purposes of this Agreement, any change of ownership of CONTRACTOR shall constitute an assignment which requires CITY approval. However, this Agreement shall run to the benefit of CITY and its successors and assigns. It is further agreed that no modification, amendment, or alteration in the terms or conditions contained herein shall be effective unless contained in a written document executed with the same formality and of equal dignity herewith.

27.5 **No Contingent Fees.** CONTRACTOR warrants that it has not employed or retained any company or person, other than a bona fide employee working solely for CONTRACTOR to solicit or secure this Agreement, and that it has not paid or agreed to pay any person, company, corporation, individual or firm, other than a bona fide employee working solely for CONTRACTOR any fee, commission, percentage, gift, or other consideration contingent upon or resulting from the award or making of this Agreement. For the breach or violation of this provision, CITY shall have the right to terminate the Agreement without liability at its discretion, to deduct from the contract price, or otherwise recover the full amount of such fee, commission, percentage, gift or consideration.

27.6 **Notice.** Whenever any party desires to give notice unto any other party, it must be given by written notice, sent by certified United States mail, with return receipt requested, addressed to the party for whom it is intended and the remaining party, at the places last specified, and the places for



giving of notice shall remain such until they shall have been changed by written notice in compliance with the provisions of this section. For the present, CONTRACTOR and CITY designate the following as the respective places for giving of notice:

CITY Charles F. Dodge, City Manager
City of Pembroke Pines
601 City Center Way, 4th Floor
Pembroke Pines, Florida 33025
Telephone No. (954) 450-1040

Copy To: Samuel S. Goren, City Attorney
Goren, Cherof, Doody & Ezrol, P.A.
3099 East Commercial Boulevard, Suite 200
Fort Lauderdale, Florida 33308
Telephone No. (954) 771-4500
Facsimile No. (954) 771-4923

CONTRACTOR {--Primary Contact Name---}, {---Primary Contact Title---}
{--Company Name---}
{--Street1---}, {---Street2---}
{--City---}, {--State/Province---} ---Postal Code---
E-mail: {--E-mail---}
Telephone No: {--Phone---}
Cell phone No: {--Primary Contact Cell Phone Number---}
Facsimile No: {--Fax---}

27.7 **Binding Authority.** Each person signing this Agreement on behalf of either party individually warrants that he or she has full legal power to execute this Agreement on behalf of the party for whom he or she is signing, and to bind and obligate such party with respect to all provisions contained in this Agreement.

27.8 **Headings.** Headings herein are for the convenience of reference only and shall not be considered in any interpretation of this Agreement.

27.9 **Exhibits.** Each exhibit referred to in this Agreement forms an essential part of this Agreement. The exhibits, if not physically attached, should be treated as part of this Agreement and are incorporated herein by reference.

27.10 **Severability.** If any provision of this Agreement or application thereof to any person or situation shall to any extent, be held invalid or unenforceable, the remainder of this Agreement, and the application of such provisions to persons or situations other than those as to which it shall have been held invalid or unenforceable, shall not be affected thereby, and shall continue in full force and effect, and be enforced to the fullest extent permitted by law.



27.11 **Entire Agreement and Conflicts.** This Agreement is intended by the parties hereto to be final expression of this Agreement, and it constitutes the full and entire understanding between the parties with respect to the subject hereof, notwithstanding any representations, statements, or agreements to the contrary heretofore made. In the event of a conflict between this Agreement, Exhibit "A", and Exhibit "B", this Agreement shall prevail, followed by Exhibit "A", and then Exhibit "B".

27.12 **Waiver.** Failure of CITY to insist upon strict performance of any provision or condition of this Agreement, or to execute any right therein contained, shall not be construed as a waiver or relinquishment for the future of any such provision, condition, or right, but the same shall remain in full force and effect.

27.13 **Attorneys' Fees.** In the event that either party brings suit for enforcement of this Agreement, each party shall bear its own attorney's fees and court costs, except as otherwise provided under the indemnification provisions set forth herein above.

27.14 **Protection of CITY Property.** At all times during the performance of this Agreement, CONTRACTOR shall protect CITY's property from all damage whatsoever on account of the work being carried on under this Agreement.

27.15 **Counterparts and Execution.** This Agreement may be executed by hand or electronically in multiple originals or counterparts, each of which shall be deemed to be an original and together shall constitute one and the same agreement. Execution and delivery of this Agreement by the Parties shall be legally binding, valid and effective upon delivery of the executed documents to the other party through facsimile transmission, email, or other electronic delivery.

27.16 **Compliance with Statutes.** It shall be the CONTRACTOR's responsibility to be aware of and comply with all statutes, ordinances, rules, orders, regulations and requirements of all local, City, state, and federal agencies as applicable.

27.16.1 **Services to be Performed at CITY Schools.** CONTRACTOR shall comply with Chapter 1012, Florida Statutes, which requires Level II background screening for individuals whom are vendors performing services at a Florida public school or district, if applicable.

27.16.2 **Background Screening.** CONTRACTOR shall comply with all requirements of Sections 1012.32 and 1012.465, Florida Statutes, and for the purpose of on-site services, all of its personnel who are to be permitted access to school grounds when students are present, will successfully complete the background screening required by the referenced statutes and meet the standards established by the statutes. This background screening will be conducted by CONTRACTOR in advance of personnel providing any services under the conditions described in the previous sentence. CONTRACTOR respectively shall bear the cost of acquiring the background screening required by Section 1012.32, Florida Statutes, and any fee imposed by the Florida Department of Law Enforcement. The failure of CONTRACTOR to perform any of the duties described in this section shall constitute a material breach of Agreement. CONTRACTOR agrees to indemnify and hold harmless CITY, its elected and



appointed officials, officers, employees, and agents from any liability in the form of physical or mental injury, death, or property damage resulting from the CONTRACTOR's failure to comply with the requirements of this Section or with Sections 1012.32 and 1012.465, Florida Statutes.

SIGNATURE PAGE FOLLOWS



IN WITNESS OF THE FOREGOING, the Parties have set their hands and seals the day and year first written above.

CITY:

CITY OF PEMBROKE PINES, FLORIDA

APPROVED AS TO FORM:

BY: _____

Print Name: _____
OFFICE OF THE CITY ATTORNEY

MAYOR ANGELO CASTILLO

ATTEST:

BY: _____

CHARLES F. DODGE, CITY MANAGER

DEBRA E. ROGERS, CITY CLERK

CONTRACTOR:

{---Company Name---}

Signed By: _____

Printed Name: _____

Title: _____

ACORD CERTIFICATE OF LIABILITY INSURANCE

DATE (MM/DD[YY])

PRODUCER

THIS CERTIFICATE IS ISSUED AS A MATTER OF INFORMATION ONLY AND CONFERS NO RIGHTS UPON THE CERTIFICATE HOLDER. THIS CERTIFICATE DOES NOT AMEND, EXTEND OR ALTER THE COVERAGE AFFORDED BY THE POLICIES BELOW.

INSURERS AFFORDING COVERAGE

INSURED

YOUR COMPANY NAME HERE

INSURER A:
INSURER B.
INSURER C.
INSURER D.
INSURER E.

Companies providing coverage

COVERAGES

THE POLICIES OF INSURANCE LISTED BELOW HAVE BEEN ISSUED TO THE INSURED NAMED ABOVE FOR THE POLICY PERIOD INDICATED. NOTWITHSTANDING ANY REQUIREMENT TERM OR CONDITION OF ANY CONTRACT OR OTHER DOCUMENT WITH RESPECT TO WHICH THIS CERTIFICATE MAY BE ISSUED OR MAY PERTAIN THE INSURANCE AFFORDED BY THE POLICIES DESCRIBED HEREIN IS SUBJECT TO ALL THE TERMS, EXCLUSIONS AND CONDITIONS OF SUCH POLICIES. AGGREGATE LIMITS SHOWN MAY HAVE BEEN REDUCED BY PAID CLAIMS.

INSR LTR	TYPE OF INSURANCE	POLICY NUMBER	POLICY EFFECTIVE DATE (MM/DDYY)	POLICY EXPIRATION DATE (MM/DDYY)	LIMITS	
	GENERAL LIABILITY <input type="checkbox"/> COMMERCIAL GENERAL LIABILITY <input checked="" type="checkbox"/> CLAIMS MADE <input type="checkbox"/> OCCUR GEN'L AGGREGATE LIMIT APPLIES PER: <input type="checkbox"/> policy <input type="checkbox"/> project <input type="checkbox"/> loc	Must Include General Liability			EACH OCCURRENCE	\$
					FIRE DAMAGE (Any one fire)	\$
				MED EXP (Any one person)	\$	
				PERSONAL & ADV INJURY	\$	
				GENERAL AGGREGATE	\$	
				PRODUCTS - COMP/OP AGG	\$	
	AUTOMOBILE LIABILITY <input type="checkbox"/> ANY AUTO <input type="checkbox"/> ALL OWNED AUTOS <input type="checkbox"/> SCHEDULED AUTOS <input type="checkbox"/> HIRED AUTOS <input type="checkbox"/> NON-OWNED AUTOS	SAMPLE CERTIFICATE				
	GARAGE LIABILITY <input type="checkbox"/> ANY AUTO				AUTO ONLY - EA ACCIDENT	\$
					OTHER THAN EA ACC	\$
					AUTO ONLY: AGG	\$
	EXCESS LIABILITY OCCUR <input type="checkbox"/> CLAIMS MADE <input type="checkbox"/> <input type="checkbox"/> DEDUCTIBLE <input type="checkbox"/> RETENTION \$				EACH OCCURRENCE	\$
					AGGREGATE	\$
						\$
						\$
	WORKERS COMPENSATION AND EMPLOYERS' LIABILITY				WC STATUTORY LIMITS	OT-ER
					E.L. EACH ACCIDENT	\$
					E.L. DISEASE - EA EMPLOYEE	\$
					E.L. DISEASE - POLICY LIMIT	\$
	OTHER					

Certificate must contain wording similar to what appears below

"THE CERTIFICATE HOLDER IS NAMED AS ADDITIONALLY INSURED WITH REGARD TO GENERAL LIABILITY"

CERTIFICATE HOLDER

ADDITIONAL INSURED; INSURER LETTER:

CANCELLATION

City of Pembroke Pines
601 City Center Way
Pembroke Pines FL 33025

SHOULD ANY OF THE ABOVE DESCRIBED POLICIES BE CANCELLED BEFORE THE EXPIRATION DATE, THE CERTIFICATE HOLDER SHALL MAIL 30 DAYS WRITTEN NOTICE TO THE PRODUCER.

City Must Be Named as Certificate Holder

AUTHORIZED REPRESENTATIVE

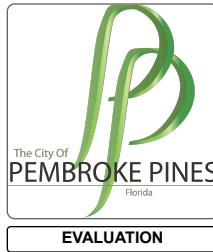

New Chiller for Studio 18

📄 Invitation For Bid

🏛️ Recreation & Cultural Arts

🔑 03113

Project ID: RE-25-07

Release Date: Tuesday, October 21, 2025

Due Date: Tuesday, December 9, 2025 2:00pm

📅 Posted 📅 Tuesday, October 21, 2025 7:23pm

📬 Bid Unsealed Tuesday, December 9, 2025 2:31pm by Gabriel Fernandez

📬 Pricing Unsealed Tuesday, December 9, 2025 2:31pm by Gabriel Fernandez

All dates & times in Eastern Time

Edit Preview

1. NOTICE

Notice is hereby given that the City Commission of the City of Pembroke Pines is seeking sealed proposals for:

IFB # RE-25-07

New Chiller for Studio 18

Solicitations may be found on the City of Pembroke Pines website under the Procurement Department at <http://www.ppines.com/index.aspx?NID=667>, and may be downloaded directly from the OpenGov platform at <https://procurement.opengov.com/portal/pembrokepines>.

For Technical Support, proposers can reach the OpenGov Service Desk between 7:00 am to 10:00 pm from Monday through Friday via the following methods:

- Chat (preferred method): Click the button in the lower right-hand corner of the portal.
- E-mail: procurement-support@opengov.com
- Phone: 1 (650) 336-7167

If additional help is needed with downloading the solicitation package please contact the Procurement Department at (954) 518-9020 or by email at purchasing@ppines.com. The Procurement Department hours are between 7:00 am to 6:00 pm on Monday through Thursday and is located at 8300 South Palm Drive, Pembroke Pines, FL 33025.

Bidders shall submit all questions regarding this bid via the City's e-Procurement Portal, located at <https://procurement.opengov.com/portal/pembrokepines>. Please note the deadline for submitting questions. All answers will be posted on the City's e-Procurement Portal. Bidders may also click "Follow" on this bid to receive an email notification when answers are posted. It is the bidder's responsibility to check the portal for updates. Only written responses issued through the OpenGov platform will be considered official for interpretations or clarifications.

Proposals will be accepted until 2:00 pm on Tuesday, December 9, 2025, electronically at

<https://procurement.opengov.com/portal/pembrokepines/projects/199987>.

Bid Opening: The sealed electronic proposals will be publicly opened at 2:30 pm, on the bid due date, by the City Clerk's Office, in the **City Clerk's Office Conference Room located on the 4th Floor in the Charles F. Dodge City Center**/City Hall Administration Building, located at 601 City Center Way, Pembroke Pines, Florida, 33025.

Virtual Bid Opening: In light of public health concerns and to ensure accessibility for all, the City encourages interested parties and the public to participate virtually via live streaming instead of attending the meeting in person. As a result, meetings may be a combination of in-person and virtual, all as provided by law. To virtually attend the bid opening, please use the Cisco Webex Meetings platform.

Virtual Meeting Details:

- WebEx Meeting Link: <https://ppines.webex.com/meet/purchasing>
- Cisco Webex Meeting Number: 717 019 586
- Join by Phone Number: +1-408-418-9388

The public may download the **Cisco Webex Meetings app** from <https://www.webex.com/downloads.html/>.

To ensure an efficient meeting process, participants are requested to mute their audio and camera during the meeting. While the public is welcome to attend the virtual bid opening, **please note that active participation and commenting will not be allowed during the proceedings.**

For further information about the bid opening or assistance in accessing the virtual meeting, please contact:

Ivan Ospinal or other Procurement Staff in the Procurement Department

City of Pembroke Pines

8300 South Palm Drive,

Pembroke Pines, FL 33025

(954) 518-9020 or 954-518-9020

purchasing@ppines.com



ADDENDA REPORT
IFB No. RE-25-07
New Chiller for Studio 18

RESPONSE DEADLINE: December 9, 2025 at 2:00 pm

Wednesday, January 14, 2026

Addenda Issued:

Addendum #1

Nov 13, 2025 7:39 AM

Please use the [See What Changed](#) link to view all the changes made by this addendum.

Kindly note that the deadline for this project has been changed. All vendors are advised to review the revised deadline and ensure timely submission of all required documents.

Addendum #2

Nov 18, 2025 11:43 AM

Please use the [See What Changed](#) link to view all the changes made by this addendum.

Please include the permanent installation of the commercial six-gauge green vinyl fence as described in the updated scope of work for the Fence Installation, including the additional requirements outlined in Section 4.2.

Ensure all materials, dimensions, and specifications listed are fully accounted for in your bid. Additionally, please note that the installation of this fence is **permanent** and should not be confused with the **temporary fence** required during the Chiller installation as specified in Section 4.7.

Addenda Acknowledgements:

Addendum #1

Proposal	Confirmed	Confirmed At	Confirmed By
Master Mechanical Services Inc	X	Dec 4, 2025 1:06 PM	Tina Pinna
Con-Mech, Inc	X	Dec 7, 2025 6:42 PM	Yudel Cubillas
ADVANCED ROOFING, INC.	X	Dec 8, 2025 12:47 PM	Debbie Giuliani
Green Alliance Inc.	X	Nov 17, 2025 4:53 PM	Ramon Duarte
Johnson Controls, Inc	X	Nov 17, 2025 1:24 PM	Christian Lambertz
KOLDAIRE, INC.	X	Dec 8, 2025 1:55 PM	Madison monti

Addendum #2

Proposal	Confirmed	Confirmed At	Confirmed By
Master Mechanical Services Inc	X	Dec 4, 2025 1:06 PM	Tina Pinna
Con-Mech, Inc	X	Dec 7, 2025 6:42 PM	Yudel Cubillas
ADVANCED ROOFING, INC.	X	Dec 8, 2025 12:47 PM	Debbie Giuliani
Green Alliance Inc.	X	Nov 18, 2025 2:14 PM	Ramon Duarte
Johnson Controls, Inc	X	Dec 9, 2025 9:45 AM	Christian Lambertz
KOLDAIRE, INC.	X	Dec 8, 2025 1:55 PM	Madison monti



QUESTION & ANSWER REPORT
IFB No. RE-25-07
New Chiller for Studio 18

RESPONSE DEADLINE: December 9, 2025 at 2:00 pm

Wednesday, January 14, 2026

Approved, Unanswered Questions

Approved, Answers Provided

1. No subject

Nov 14, 2025 7:42 AM

Question: Have the plans for the project been approved by the Building Department? Based on the scope for this project if we Bid plans before City Approval there could be issues during plan review that impact scope and cost.

Nov 14, 2025 7:42 AM

Answered by Ivan Ospinal: No, the plans have not been submitted to the Building Department. It is the vendor's responsibility to submit the full permit package (permit applications, plans, spec sheets, etc.). If delays occur during plan review, at no fault of the contractor, it will not count against the contract timeline.

Nov 20, 2025 10:04 AM

2. No subject

Nov 14, 2025 7:43 AM

Question: Is Schedule 80 CPVC acceptable for underground chilled water pipe.

Nov 14, 2025 7:43 AM

Answered by Ivan Ospinal: Per the engineer, yes—Schedule 80 CPVC is acceptable.

Nov 20, 2025 10:04 AM

3. No subject

Nov 14, 2025 9:02 AM

Question: Scope of work 4.1 references S-1.0 for the concrete slab. there does not appear to be an S-1.0 in the plan set.

Nov 14, 2025 9:02 AM

Answered by Ivan Ospinal: Sheet M-1 includes the foundation pad details for the concrete slab.

Nov 20, 2025 10:04 AM

4. No subject

Nov 17, 2025 12:01 PM

Question: Carrier ,York and Daikin are acceptable alternates for chiller. Please confirm we can use alternate manufacturer for controls to match Chiller.

Nov 17, 2025 12:01 PM

Answered by Ivan Ospinal: The basis of design is Trane. Carrier, York, and Daikin are considerable alternates provided they are demonstrated to be equivalent and fully comply with all project specifications. Alternates would have to be approved by both Engineer and City Staff, and pricing submitted as a separate line item to the base bid price for the Trane unit.

Nov 20, 2025 10:05 AM

5. No subject

Nov 17, 2025 12:07 PM

Question: Clarify.... Note 12 on equipment schedule calls for a Single VFD for pump package. sequence and controls diagram calls for Primary and stand-by pumps with separate VFD"s.

Nov 17, 2025 12:07 PM

Answered by Ivan Ospinal: Per the engineer: Bid the project per the controls diagram, using two VFDs.

Nov 20, 2025 10:05 AM

6. License Requirement

Oct 23, 2025 2:19 PM

Question: Is a Class A HVAC license acceptable for responding to this bid?

Oct 23, 2025 2:19 PM

Answered by Ivan Ospinal: Yes, a Class A HVAC license is acceptable. All licensing requirements in the bid documents must still be met.

Nov 20, 2025 10:04 AM

7. Walk-Through Questions

Nov 3, 2025 8:07 AM

Question: 1. Will the new chiller run on stand-alone controls or is it expected to connect to an existing BMS/BAS in the building? There was no indication in the walkthrough of a central control system in the building. The existing AHUs seem to be working off t-stats on the wall. 2. Will the sidewalk need to be left accessible to the public once the temporary fence is installed during the pad install and chiller install? 3. Will we be able to use the isolation valves we were shown across the street to isolate the existing CHW piping to cap them before the chiller tie-in and avoid freezing or hot taps? 4. When do the 60 days to complete the project start? Once contract is signed or once we receive the chiller from the factory? 5. Will we be able to complete all work during normal business hours or will the shutdown and tie-in need to be done during after-hours or on a weekend? 6. Other than notes and summary on provided plans, are there or will there be a set of complete specifications? 7. On Plans - Schedule Note calls out the refrigerant to be R454B. Will you accept a Low-GWP "R-32"? 8. On Plans and Section 4 - The Schedule/Notes make no reference to the Condenser Coil. What type of coil do you want. The more robust Aluminum Fin Copper Tube or the lesser Microchannel/Lanced aluminum? 9. On Plans and Section 4 - The Schedule/Notes make no reference to unit protection/control. Do you need any of the following: a. Disconnect option – Non-Fused Disconnect b. BACnet or Energy Management Module – BMS integration c. Hail Guards 10. The Schedule/Notes make no reference to coatings. Are you in need of environmental coating on the cabinet, coils or any exposed metals? If so, what standards are we to meet? 11. Section 4 (4.1 Scope of Work) Notes/Scope of Work refer to the warranty to be 5-year compressor parts warranty. Would you prefer a more complete warranty (example, 5.5-Year ALL Parts and Factory Labor Warranty)? 12. Section 4 (4.2 General Requirements) Notes/Scope of Work refer to training "Provide training for City staff on the proper operation and maintenance of the new systems." Can you please give a more elaborate definition (example, how many hours, is this to be recorded, do we need to provide multiple classes...) 13. Section 4 (4.8 Working Hours) Notes/Scope of Work refer to completing the project in 60 calendar days. Some of the approved manufactures are currently (manufacture/production) 19-20 weeks out. Will you extend this time frame to allow for more flexibility on completion and competitive pricing?

Nov 3, 2025 8:07 AM

Answered by Ivan Ospinal: 1. There is no existing BMS in the building. This project introduces a new BMS to control the chiller. The existing air handlers may be tied into the BMS at a later date. See Sheet M-2 (SC+ to be added). 2. Yes. The sidewalk providing access to the building must remain accessible. Proper signage and safety measures must be in place. 3. Yes. The isolation valves across the street may be used to isolate the CHW piping for capping to avoid freezing or hot taps. Coordinate with the facility manager prior to work. 4. The 60 days begin when the City issues the Notice to Proceed (NTP) after the contract is fully executed. Equipment lead times will not count toward the contract duration. 5. A new electrical service is required per the plans. The vendor must coordinate and schedule the installation and connection of the new service prior to removing the existing service in order to minimize downtime. Any

QUESTION & ANSWER REPORT

IFB No. RE-25-07

New Chiller for Studio 18

future coordination and planning regarding shutdown logistics will be discussed after award. 6. No. The signed and sealed plans contain all specifications. Provide and install a new 40-ton air-cooled chiller (Trane CGAM040A2 or approved equal). Alternate equipment must be approved by both the Engineer and City staff. 7. No. Per the engineer, R454B must be used as indicated. 8. Aluminum Fin Copper Tube coils are preferred for durability and efficiency. 9. Yes, we require a Non-Fused Disconnect and BACnet a. Required b. Required for BMS integration c. Optional but recommended based on location 10. Yes, environmental coatings are required. All equipment must meet the project's corrosion-resistance standards, including a minimum 15,000-hour salt spray corrosion protection rating. 11. A minimum of 5 years is required. Longer warranties are acceptable and encouraged. 12. Training must include operation of the new chiller, proper shutdown procedures, and any key maintenance or system-specific information. 13. Yes. The City acknowledges manufacturer delays and is open to discussing a reasonable extension. See also the response to Question #5 regarding NTP timing.

Nov 20, 2025 11:53 AM

8. prevailing wage rate scale

Nov 21, 2025 9:57 AM

Question: is this project a Davis-Bacon wage job?

Nov 21, 2025 9:57 AM

Answered by Ivan Ospinal: This is not a David Bacon wage job.

Dec 1, 2025 4:24 PM

9. Corrosion-resistance standards

Nov 24, 2025 4:33 PM

Question: in the last Q&A 10. The Schedule/Notes make no reference to coatings. Are you in need of environmental coating on the cabinet, coils or any exposed metals? If so, what standards are we to meet? 10. Yes. Environmental coatings are required per the corrosion-resistance standards in the project specifications. Please provide the corrosion-resistance standards, we reviewed the project specifications and plans and found no mention of it.

Nov 24, 2025 4:33 PM

Answered by Ivan Ospinal: Yes, environmental coatings are required. All equipment must meet the project's corrosion-resistance standards, including a minimum 15,000-hour salt spray corrosion protection rating.

Dec 1, 2025 4:24 PM

10. No subject

Nov 24, 2025 8:48 AM

QUESTION & ANSWER REPORT

IFB No. RE-25-07

New Chiller for Studio 18

Question: Please provide information of the current HVAC control Co. for this building.

Nov 24, 2025 8:48 AM

Answered by Ivan Ospinal: See answer to previous question #7.9 on subject.

Dec 1, 2025 4:24 PM

11. Refrigerant

Nov 24, 2025 4:35 PM

Question: In reference to the listed approved refrigeration (R454B), this will limit the competition to two manufacturers. The only chiller manufacturers of this size unit (40 tons) that are R454B are Trane and York. This will exclude Daikin and Carrier. FYI - R-454B refrigerant is composed of approximately 68.9% R-32 (difluoromethane). The remaining percentage is R-1234yf (2,3,3,3-tetrafluoropropene) at 31.1%

Nov 24, 2025 4:35 PM

Answered by Ivan Ospinal: See answer to previous question # 7.7 on subject

Dec 1, 2025 4:24 PM

12. Controls

Nov 24, 2025 4:35 PM

Question: On Controls are you looking to add a Front End in addition to what is shown in the controls diagram?

Nov 24, 2025 4:35 PM

Answered by Ivan Ospinal: See answer to previous question #7.9 on subject.

Dec 1, 2025 4:24 PM

13. No subject

Nov 24, 2025 5:04 PM

Question: In reference to the listed approved refrigeration (R454B), this will limit the options and not make it a competitive bid. As per EPA regulations, Effective January 1, 2025: The manufacturing and import of most new HVAC systems using refrigerants with a GWP of 700 or higher are prohibited. R-32 Refrigerant is 675 and meets all EPA regulations. R-454B refrigerant is composed of approximately 68.9% R-32 (difluoromethane). The remaining percentage is R-1234yf (2,3,3,3-tetrafluoropropene) at 31.1% The only chiller manufacturers of this size unit (40 tons) that are R454B are Trane and York. This will exclude Daikin and Carrier.







Nov 24, 2025 5:04 PM

Answered by Ivan Ospinal: See answer to previous question #7.7 on subject.

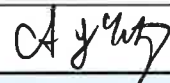
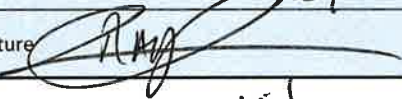
Dec 1, 2025 4:24 PM

IFB # RE-25-07 New Chiller for Studio 18

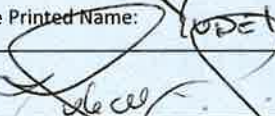
Date: 10/30/2025 Meeting Location: 1101 Poinciana Drive, Pembroke Pines, FL 33025

PRE-BID ATTENDANCE SHEET			
1)	Company Name: <u>Carrier</u>	Representative Printed Name: <u>Bradley Katzman</u>	E-mail: <u>Bradley.katzman@carrier.com</u>
	Address: <u>5440 N.W. 33rd Ave Ft Lauderdale FL 33307</u>	Signature: 	Phone Number: <u>954.439.8584</u>
2)	Company Name: <u>JCI</u>	Representative Printed Name: <u>Christian Lambertz</u>	E-mail: <u>Christian.Lambertz@SEI.com</u>
	Address: <u>15901 SW 29th St Miramar FL 33027</u>	Signature: 	Phone Number: <u>786 792 9892</u>
3)	Company Name: <u>ADVANCED AIR SYSTEMS</u>	Representative Printed Name: <u>RAYMOND VIGELLES</u>	E-mail: <u>RAYMOND@ADVANCEDAIRSYSTEMS.COM</u>
	Address: <u>2100 NW 21st Ave Ft, FL 33311</u>	Signature: 	Phone Number: <u>(954)-309-1029</u>
4)	Company Name: <u>Air Ways Mechanical</u>	Representative Printed Name: <u>Vilma Gracia</u>	E-mail: <u>hg@airwaysmechanical.com</u>
	Address: <u>5011 NW 37 Ave Tamava FL</u>	Signature: 	Phone Number: <u>954 368 3992</u>
5)	Company Name: <u>KOLDAIRE, INC</u>	Representative Printed Name: <u>FRANK MONTI JR</u>	E-mail: <u>FMONTI@KOLDAIRE.NET</u>
	Address: <u>11955 NW 37th St, Coral Springs FL</u>	Signature: 	Phone Number: <u>754-224-6746</u>
6)	Company Name: <u>Everglades Pro Svc, Corp</u>	Representative Printed Name: <u>Jose Ruiz</u>	E-mail: <u>info@everglades-services.com</u>
	Address: <u>8430 Bird Rd, Miami, FL 33155</u>	Signature: 	Phone Number: <u>305-215-4472</u>
7)	Company Name: <u>CON-MECH, INC</u>	Representative Printed Name: <u>YODEL CUBILLAS</u>	E-mail: <u>INFO@CON-MECH.COM</u>
	Address: <u>9802 NW 80th Ave, Unit 38 Hialeah Gardens, FL 33016</u>	Signature: 	Phone Number: <u>786-918-3310</u>
8)	Company Name: <u>ISMAEL JCR MECHANICAL CONTRACTOR INC</u>	Representative Printed Name: <u>ISMAEL VENTURA</u>	E-mail: <u>office@jcrmechanicalcontractor.com</u>
	Address: <u>2520 W 74th St Hialeah FL 33016</u>	Signature: 	Phone Number: <u>786/970-9855</u>

WAIVER AND RELEASE OF LIABILITY



As a participant and by signing this PRE-BID ATTENDANCE SHEET, I hereby waive, release, and indemnify the City of Pembroke Pines, its officers, agents, employees, commission, insurers and volunteers (collectively, the "City") from any and all claims, liability, injury, causes of action, suits, demands and/or damage of whatever kind, (collectively, "Claims") made by myself or any party on my behalf whether caused in whole or in part by any negligence of the City, or otherwise, in connection with my participation in the above-referenced program/activity. I hereby further hold the City harmless from any and all Claims that may be incurred in connection with my participation in the above-referenced site visit for the above mentioned project. By signing this form and as a participant in this PRE-BID MEETING / SITE VISIT, I affirm that I am physically able to participate in the City of Pembroke Pines's PRE-BID MEETING / SITE VISIT. By signing this form I affirm that I understand and recognize there are risks and hazards associated with said activity and that I am waiving and releasing the Claims described above. This Waiver and Release shall be binding upon myself, and my respective successors, heirs, assigns, executors, administrators, spouse and next of kin. I affirm that I am aware of the current recommendations from the CDC, the State of Florida, Broward County, and the City related to Covid-19 and agree to abide by those recommendations as applicable to any activity related to this site visit.

IFB # RE-25-07 New Chiller for Studio 18

Date: 10/30/2025

Meeting Location: 1101 Poinciana Drive, Pembroke Pines, FL 33025

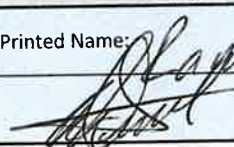
PRE-BID ATTENDANCE SHEET

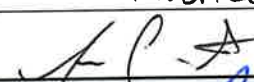

1)	Company Name: <u>Green Alliance, Inc</u>	Representative Printed Name: <u>Raymon Wolfe</u>	E-mail: <u>rwolfe@greenalliancecorp.com</u>
	Address: <u>14996 SW 28th Terr</u>	Signature: 	Phone Number: <u>786 319 7023</u>
2)	Company Name: <u>Abundant Air Heating & Cooling</u>	Representative Printed Name: <u>Evan Stinson</u>	E-mail: <u>abundantairhvac@outlook.com</u>
	Address: <u>1295 Summit Run Circle</u>	Signature: 	Phone Number: <u>561-586-6689</u>
3)	Company Name: <u>Aelo & Company</u>	Representative Printed Name: <u>Demetrius Lane</u>	E-mail: <u>info@AeloContainers.com</u>
	Address: <u>4919 SW 23rd St</u>	Signature: 	Phone Number: <u>954-881-2682</u>
4)	Company Name: <u>Here Rentals</u>	Representative Printed Name: <u>Fabrice Constant</u>	E-mail: <u>Fabrice.Constant@hereRentals.com</u>
	Address: <u>5850 NW 77th Ct, Miami, FL</u>	Signature: 	Phone Number: <u>561-592-9198</u>
5)	Company Name: <u>CWI Industrial</u>	Representative Printed Name: <u>Donald Conner</u>	E-mail: <u>cwioc20@gmail.com</u>
	Address: <u>Frostproof FL</u>	Signature: _____	Phone Number: _____
6)	Company Name: <u>Comelvis Grady</u>	Representative Printed Name: _____	E-mail: _____
	Address: _____	Signature: _____	Phone Number: _____
7)	Company Name: _____	Representative Printed Name: _____	E-mail: _____
	Address: _____	Signature: _____	Phone Number: _____
8)	Company Name: _____	Representative Printed Name: _____	E-mail: _____
	Address: _____	Signature: _____	Phone Number: _____

WAIVER AND RELEASE OF LIABILITY

As a participant and by signing this PRE-BID ATTENDANCE SHEET, I hereby waive, release, and indemnify the City of Pembroke Pines, its officers, agents, employees, commission, insurers and volunteers (collectively, the "City") from any and all claims, liability, injury, causes of action, suits, demands and/or damage of whatever kind, (collectively, "Claims") made by myself or any party on my behalf whether caused in whole or in part by any negligence of the City, or otherwise, in connection with my participation in the above-referenced program/activity. I hereby further hold the City harmless from any and all Claims that may be incurred in connection with my participation in the above-referenced site visit for the above mentioned project. By signing this form and as a participant in this PRE-BID MEETING / SITE VISIT, I affirm that I am physically able to participate in the City of Pembroke Pines's PRE-BID MEETING / SITE VISIT. By signing this form I affirm that I understand and recognize there are risks and hazards associated with said activity and that I am waiving and releasing the Claims described above. This Waiver and Release shall be binding upon myself, and my respective successors, heirs, assigns, executors, administrators, spouse and next of kin. I affirm that I am aware of the current recommendations from the CDC, the State of Florida, Broward County, and the City related to Covid-19 and agree to abide by those recommendations as applicable to any activity related to this site visit.

IFB # RE-25-07 New Chiller for Studio 18

Date: 11/13/2025 Meeting Location: 1101 Poinciana Drive, Pembroke Pines, FL 33025

PRE-BID ATTENDANCE SHEET			
1)	Company Name: <u>POWERITE</u>	Representative Printed Name: <u>ROBERT KENNEDY</u>	E-mail: <u>RKENNEDY@WEAREDONERITE.COM</u>
	Address: <u>4042 NW 133RD ST OPALOCKA</u>	Signature: 	Phone Number: <u>9-232-7046</u>
2)	Company Name: <u>MASTER Mechanical Services</u>	Representative Printed Name: <u>Sean Pinn</u>	E-mail: <u>SPinn@MasterMechanicalServices.com</u>
	Address: <u>15181 NW 33 PL</u>	Signature: 	Phone Number: <u>305 825-3004</u>
3)	Company Name:	Representative Printed Name:	E-mail:
	Address:	Signature:	Phone Number:
4)	Company Name:	Representative Printed Name:	E-mail:
	Address:	Signature:	Phone Number:
5)	Company Name:	Representative Printed Name:	E-mail:
	Address:	Signature:	Phone Number:
6)	Company Name:	Representative Printed Name:	E-mail:
	Address:	Signature:	Phone Number:
7)	Company Name:	Representative Printed Name:	E-mail:
	Address:	Signature:	Phone Number:
8)	Company Name:	Representative Printed Name:	E-mail:
	Address:	Signature:	Phone Number:

WAIVER AND RELEASE OF LIABILITY

As a participant and by signing this PRE-BID ATTENDANCE SHEET, I hereby waive, release, and indemnify the City of Pembroke Pines, its officers, agents, employees, commission, insurers and volunteers (collectively, the "City") from any and all claims, liability, injury, causes of action, suits, demands and/or damage of whatever kind, (collectively, "Claims") made by myself or any party on my behalf whether caused in whole or in part by any negligence of the City, or otherwise, in connection with my participation in the above-referenced program/activity. I hereby further hold the City harmless from any and all Claims that may be incurred in connection with my participation in the above-referenced site visit for the above mentioned project. By signing this form and as a participant in this PRE-BID MEETING / SITE VISIT, I affirm that I am physically able to participate in the City of Pembroke Pines's PRE-BID MEETING / SITE VISIT. By signing this form I affirm that I understand and recognize there are risks and hazards associated with said activity and that I am waiving and releasing the Claims described above. This Waiver and Release shall be binding upon myself, and my respective successors, heirs, assigns, executors, administrators, spouse and next of kin. I affirm that I am aware of the current recommendations from the CDC, the State of Florida, Broward County, and the City related to Covid-19 and agree to abide by those recommendations as applicable to any activity related to this site visit.